

Learning from the Future through Digital Twin Enabled Capacity Planning

D-SIMLAB Technologies Pte Ltd

Fab Owners Alliance
Fab Star Webinar

19 September 2024

About D-SIMLAB Technologies

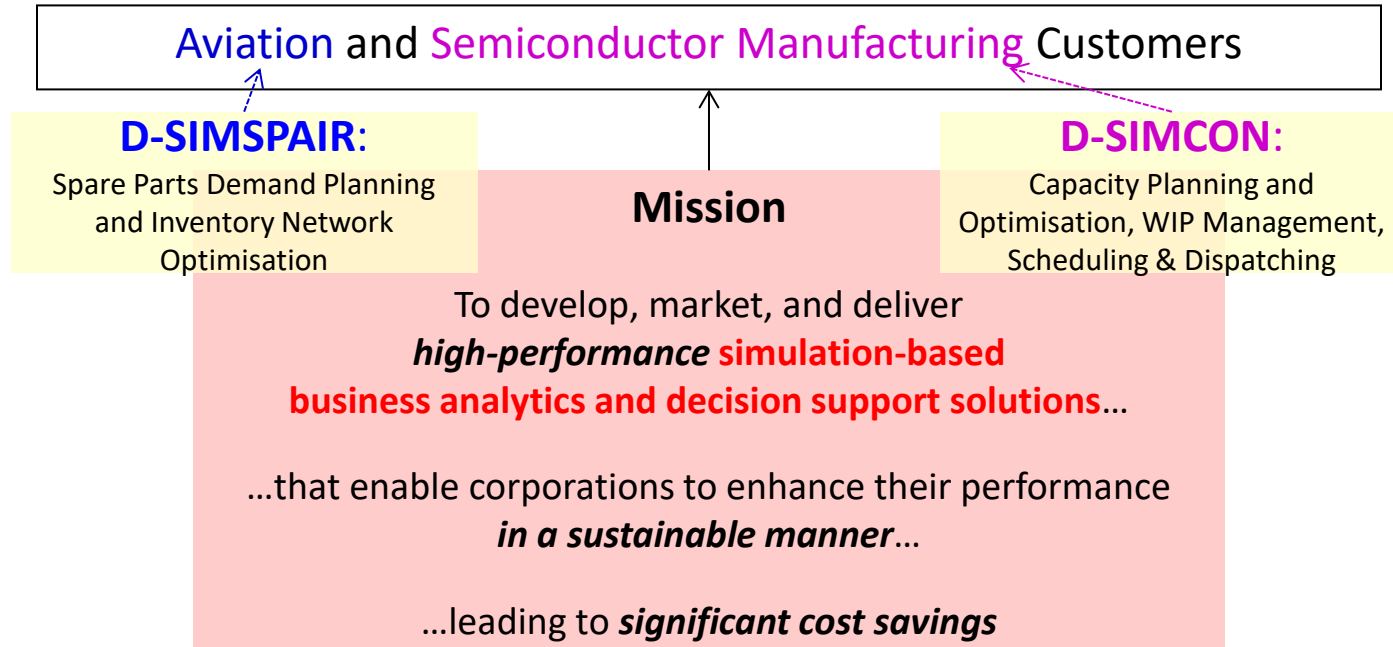

D-SIMLAB Technologies – Global Presence

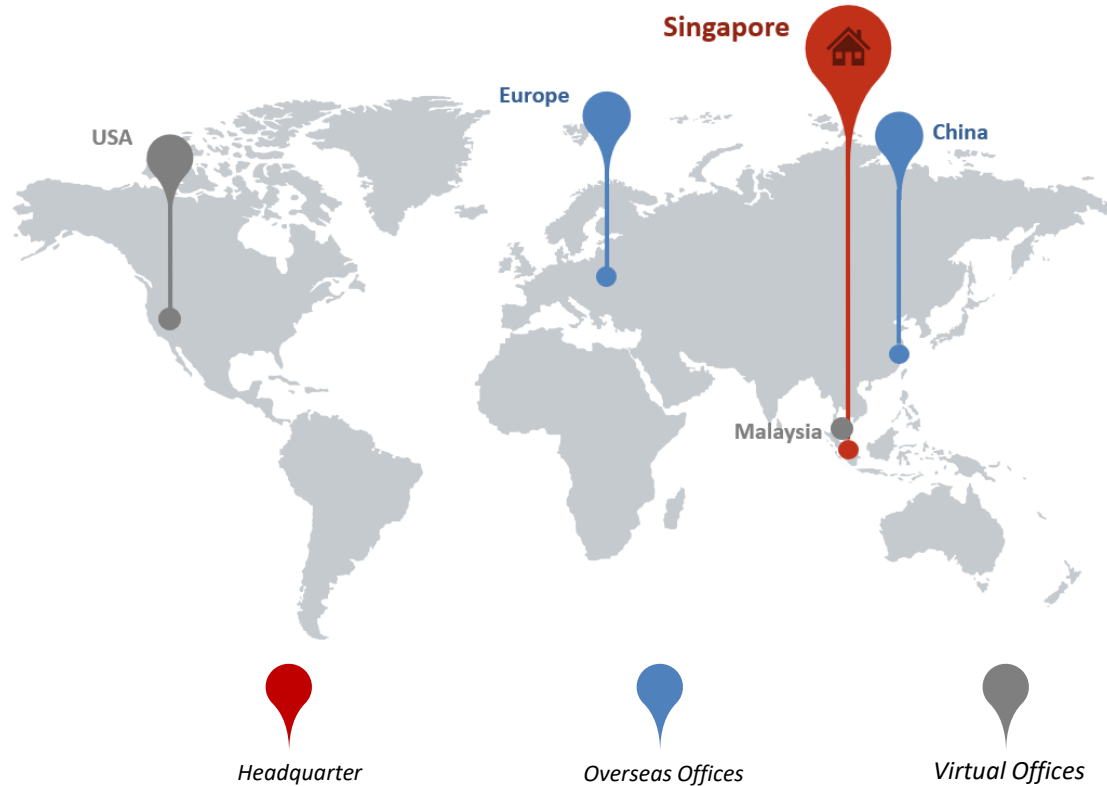

Overview

- (1) Semiconductor Manufacturing and Digital Twins
- (2) From Predictive to Prescriptive Operations Planning
- (3) Where AI comes into the picture
- (4) Integrated, Multi-Level D-SIMCON Digital Twin Suite

Digital Twins for Semiconductor Manufacturing



Energy Management

Monitor and optimize energy usage



Product Quality Control

Identify factors affecting the product quality and optimize production parameters



Production Planning and Operations Management

Predict potential bottlenecks and optimize the production plans

Today's Focus



Equipment Health Monitoring and Maintenance

Preventive maintenance to reduce unscheduled equipment downtime

SEMI Paradigm

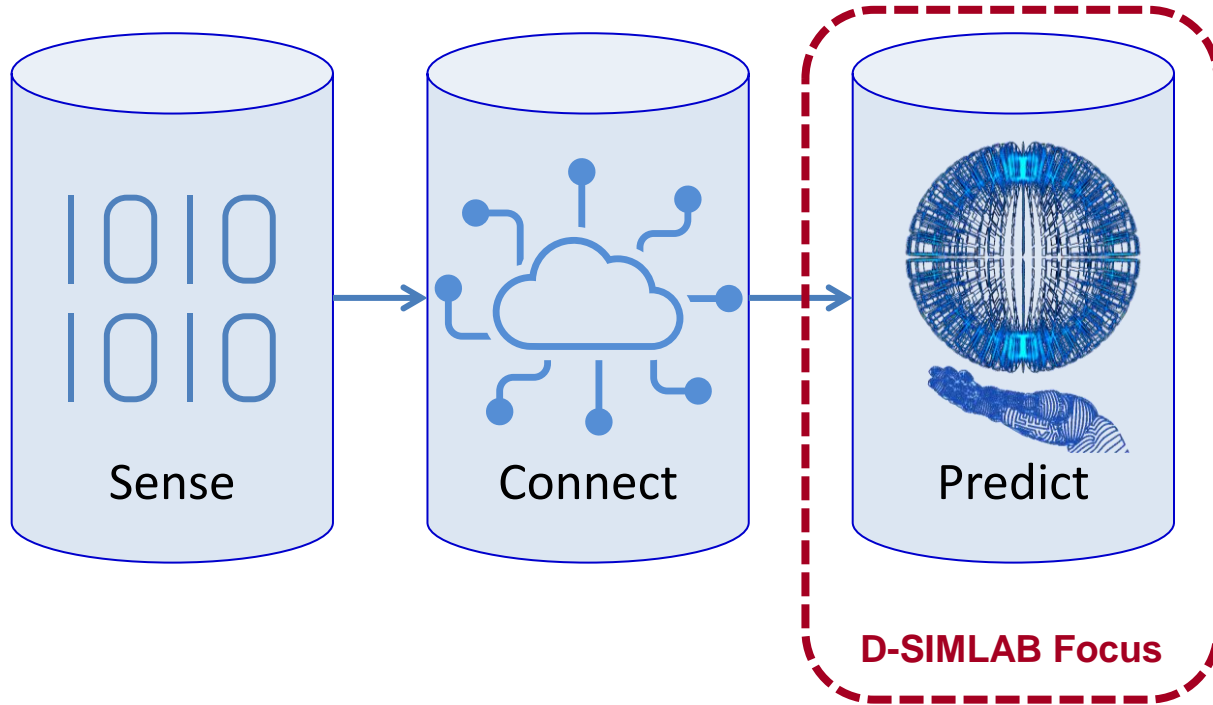

Why high-quality predictions are so essential...

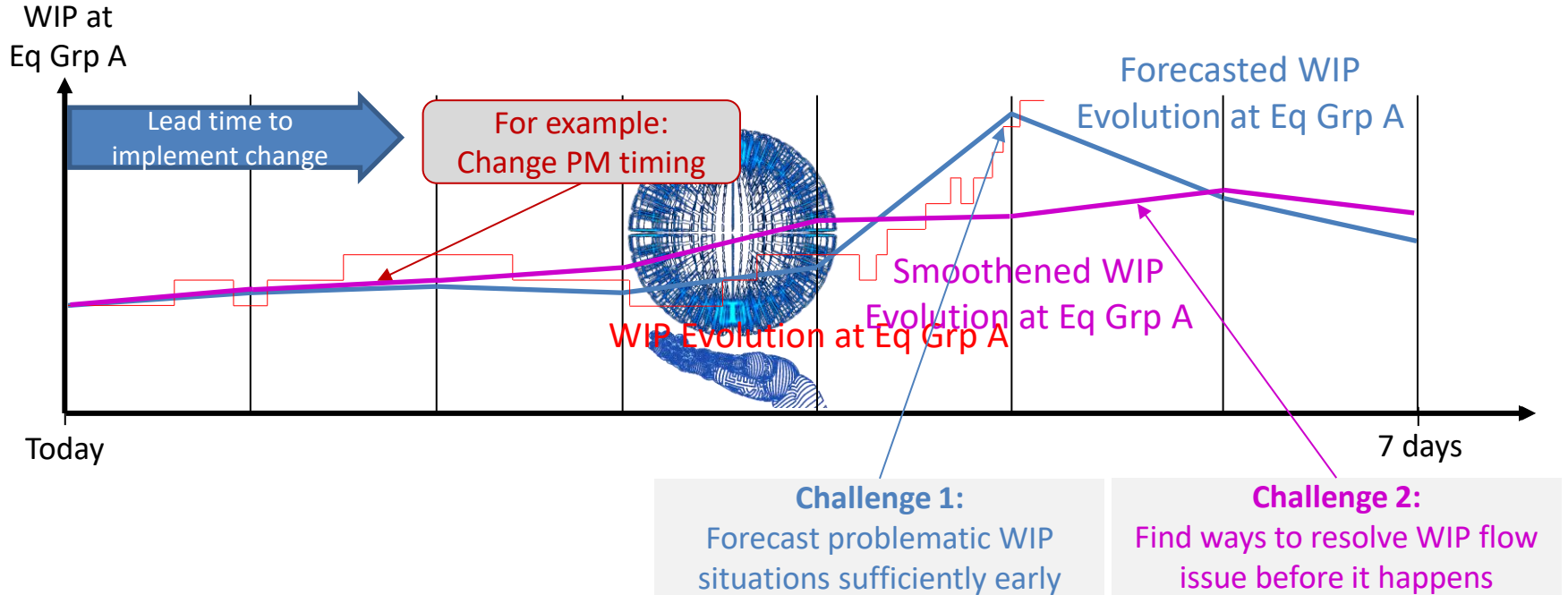

What “Simulation” is about...

- **Imitate** the material flow operations in a wafer fab as realistically as possible **in a computer model**
 - **React to key drivers** in the same (or at least similar) way as compared to the actual fab
 - Only this will allow to make predictions
- 
- **Experiment with the computer model** instead of the actual fab
 - Analyse different fab performance scenarios and test new concepts **without any disruption of the real system**

Dynamic Capacity Planning – Underlying Simulation Approach

High-fidelity simulation of dynamics of lots moving through the Fab and the allocation to tools operations

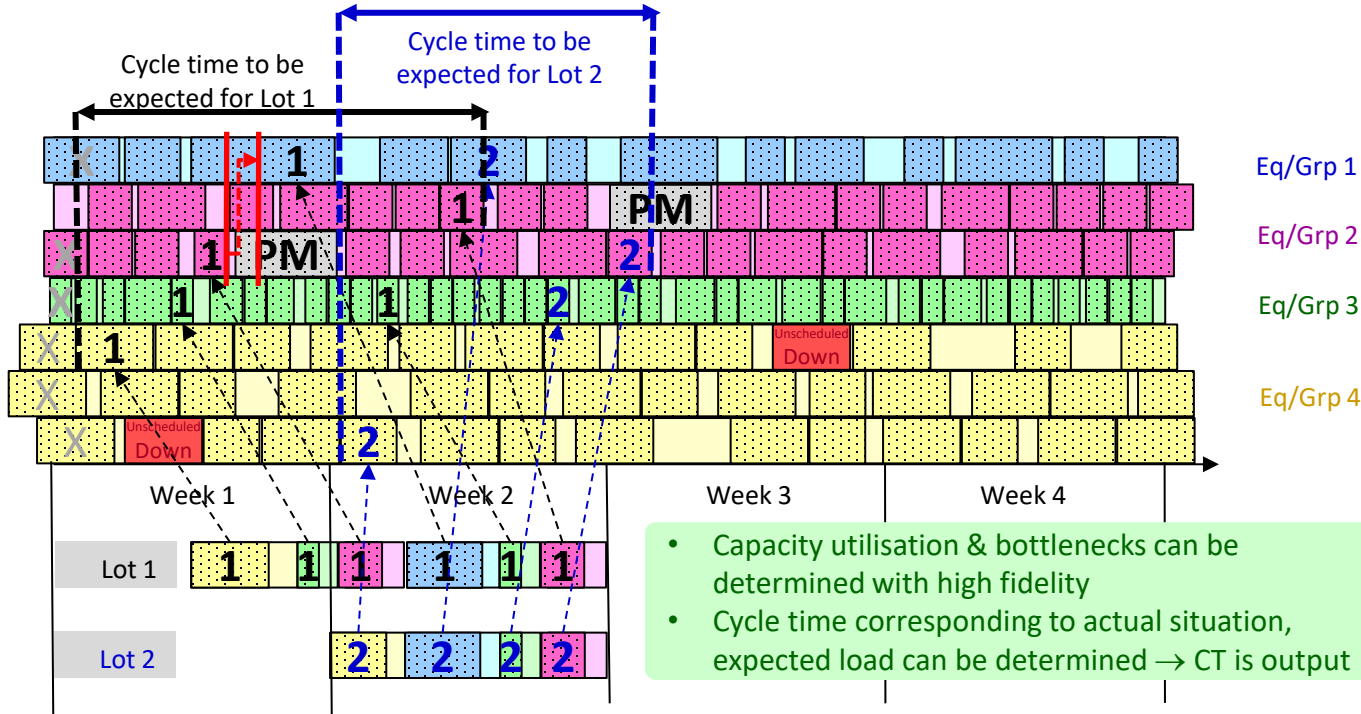

How to portray a complex wafer fab with sufficient fidelity

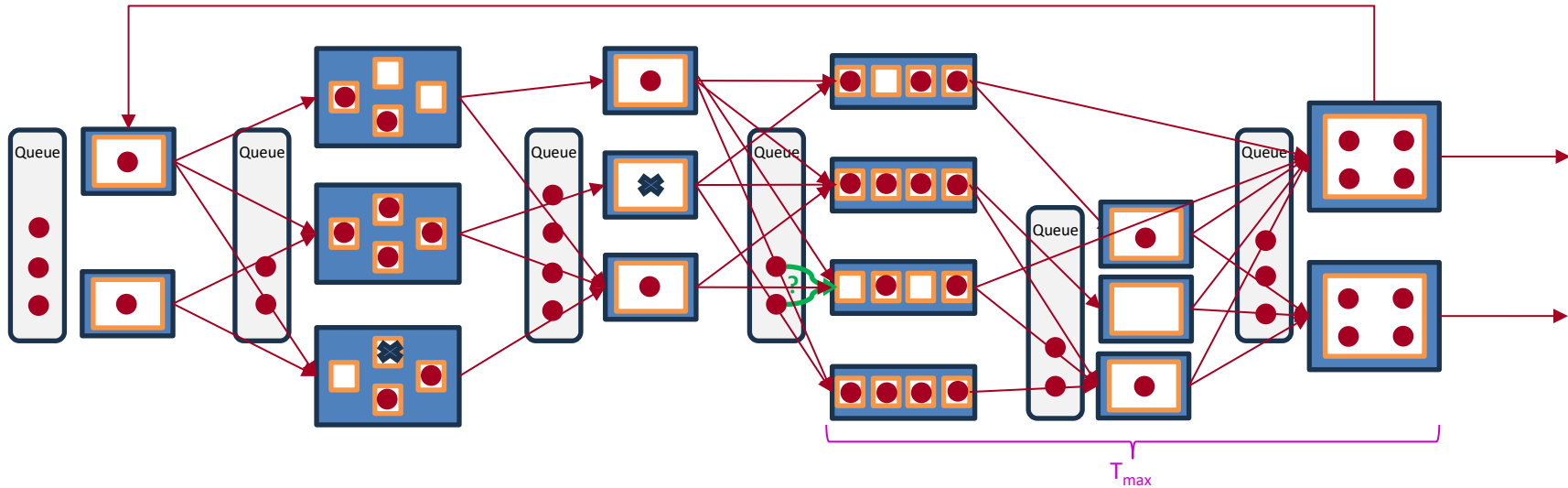

- Many hundreds of tools
- Several dozens of routes with
 - ... many hundreds of production steps
 - ... re-entrant flows
- Many thousands of WIP lots

- Real-Time Status
 - ...such as tool/chamber downs
- Batching
- Dispatching/scheduling rules
- Queue time constraints

This granularity should not be sacrificed!

How to portray a complex wafer fab with sufficient fidelity

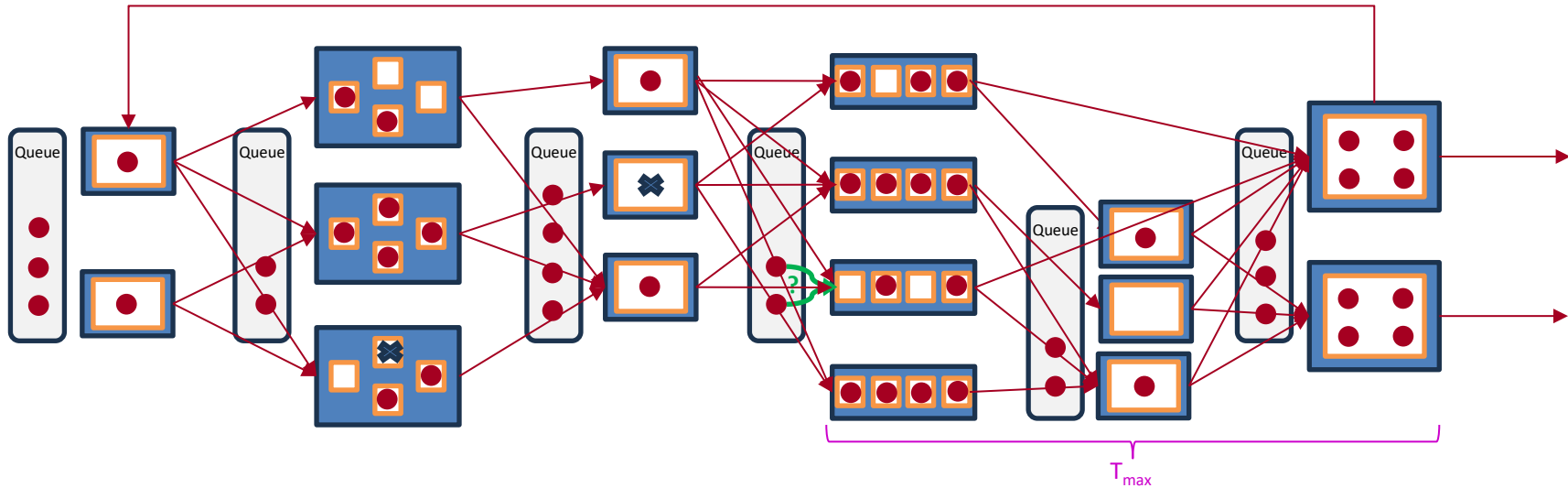

- Cycle Time = Σ Processing Times + Σ Queue Times
- Prediction of queue times is the real challenge!
- Dependent on many decision variables controlling WIP flow **in between** tools (batching, dispatching, scheduling rules)

- Many factors, variables, inter-tool dependencies to be considered
- Correlations are very difficult to detect
- Very important to portray and understand the causalities → that's what simulation is about!

Purpose of a Digital Twin

Digital Twin: Integrated computer model that **represents**, **connects and synchronizes** a part of or the whole physical manufacturing system or process, enabled by **historical and real-time** data from the physical system *

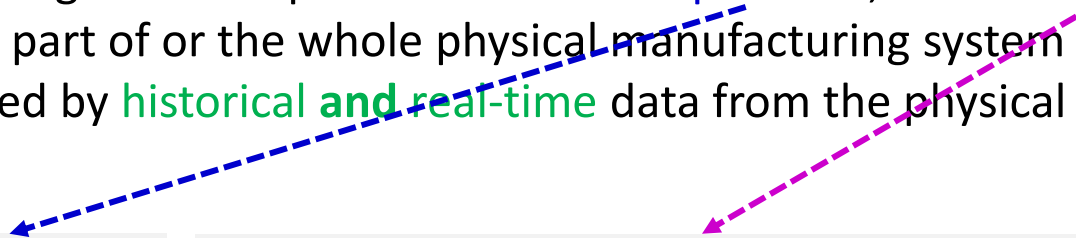

Capability to portray the behaviour of the system

- Not a purpose of a Digital Twin per se
 - Rather means to improve the quality of “represent”
 - Increase the degree of automation for ETL
 - Detect even recent changes/trends in the underlying behavioral patterns of the real system
- 
- Make Simulation also applicable for operational decision-making purposes

*Shao, G. and D. Kibira. 2018. Digital Manufacturing: Requirements and Challenges for Implementing Digital Surrogates. In Proceedings of the 2018 Winter Simulation Conference. Gothenburg (Sweden). 1226-1237.

D-SIMCON Dynamic Capacity and Material Flow Performance (DCMF) Planner

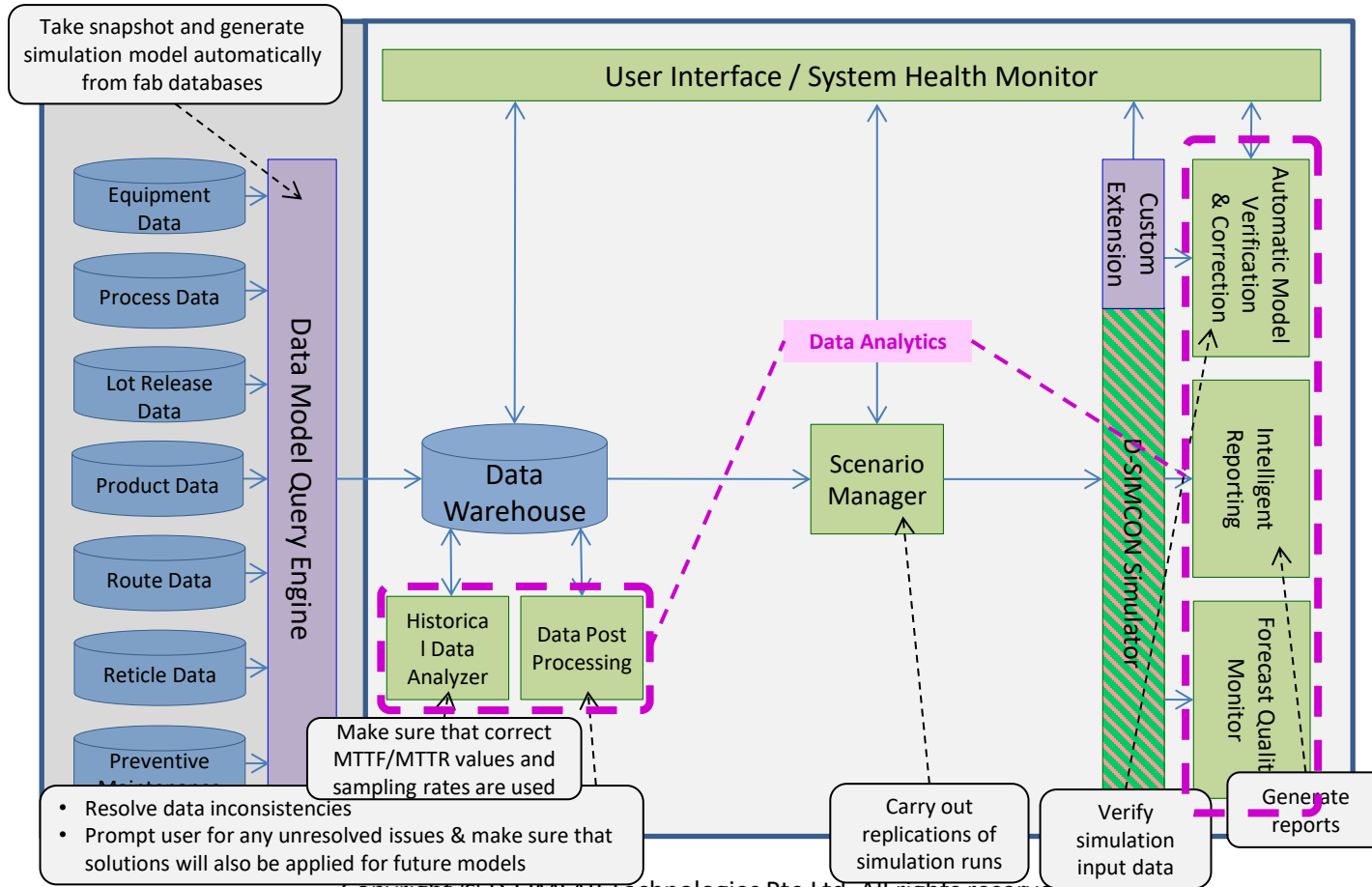

D-SIMCON DCMF Planner – Use Cases and Benefits

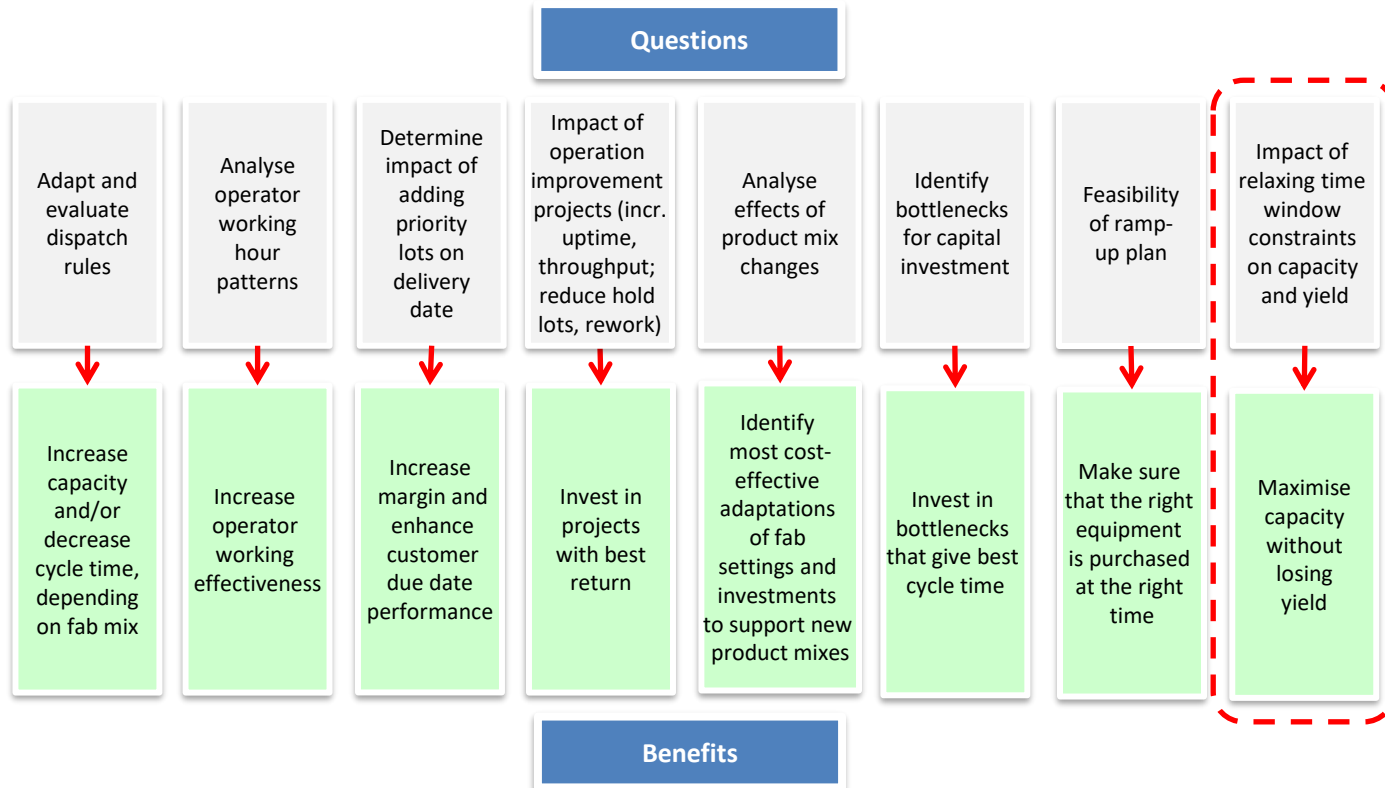

Overview

- (1) Semiconductor Manufacturing and Digital Twins
- (2) From Predictive to Prescriptive Operations Planning
- (3) Where AI comes into the picture
- (4) Integrated, Multi-Level D-SIMCON Digital Twin Suite

SEMI Paradigm

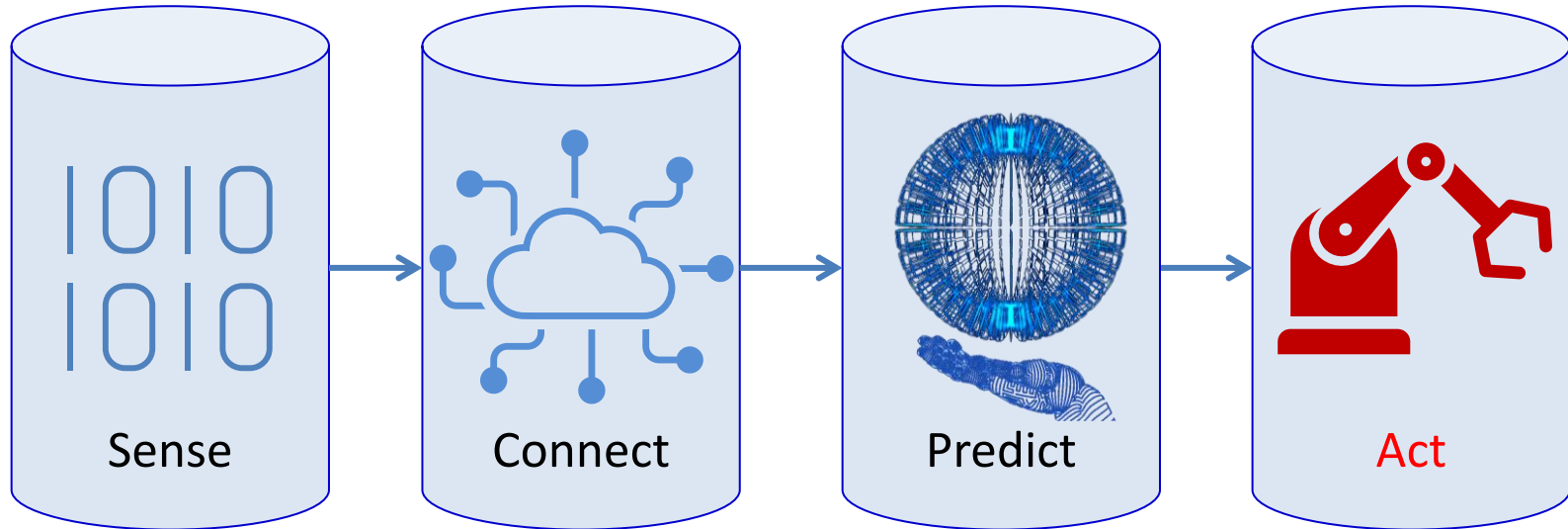

The more you can sense, the more you can predict...
...but you also need to **act!**

Predicted issues & unexpected events → Some kind of reaction might be required

Myriad of options...

- Some of them are certainly not so good
- Some of them are better
- Many of them → No idea whether they are good...

A green arrow pointing downwards from the list of options to the optimization goal.

Find the best possible reaction out of many available options! →
“Optimise”!

D-SIMCON DCMF Planner – Augmentation with Optimisation Capability

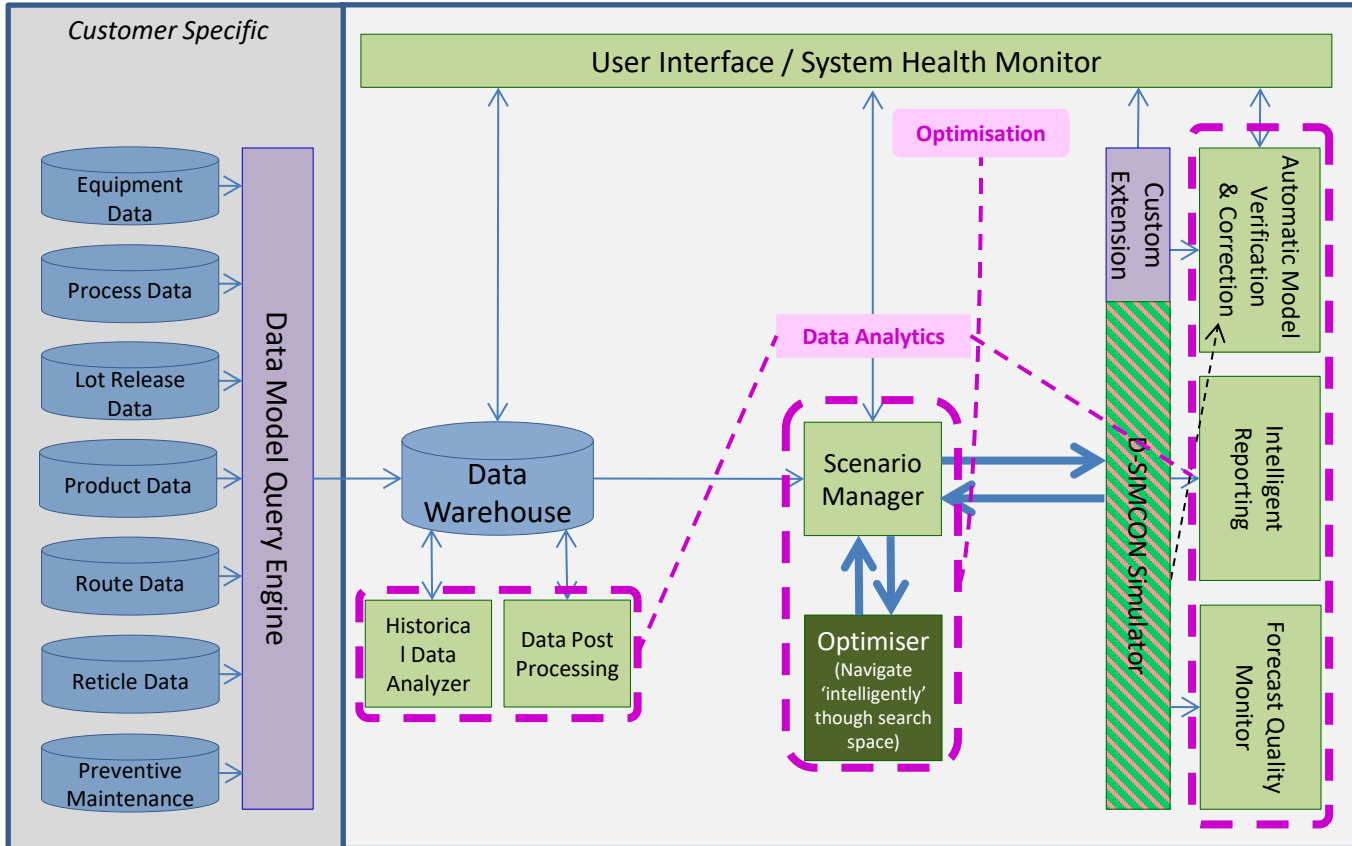

Fab Optimisation → General Considerations

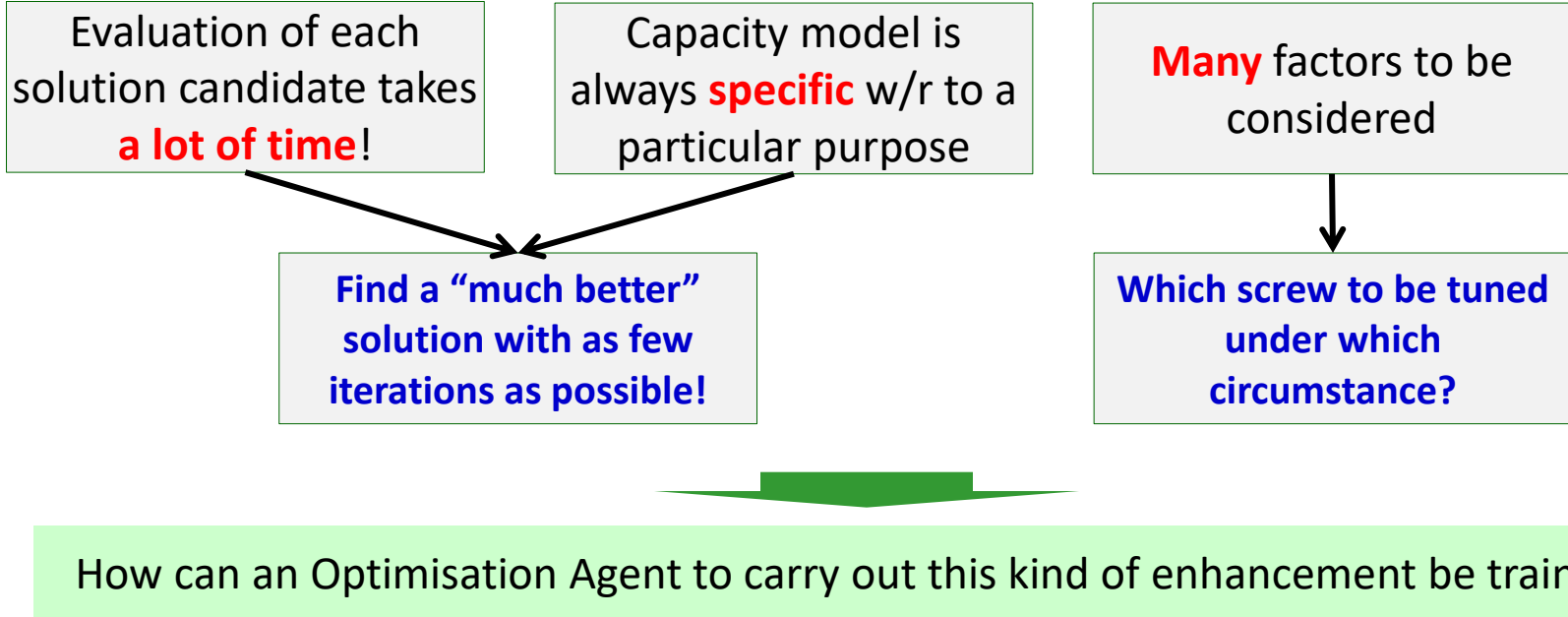

Overview

- (1) Semiconductor Manufacturing and Digital Twins
- (2) From Predictive to Prescriptive Operations Planning
- (3) Where AI comes into the picture
- (4) Integrated, Multi-Level D-SIMCON Digital Twin Suite

Where AI and Digital Twins come together...

- Recent advancements in Artificial Intelligence
 - Huge potential in Semiconductor Manufacturing → Increase efficiency and performance of factories
- Wafer fabrication facilities are producing an enormous amount of data every day
 - Very valuable for the training of AI models

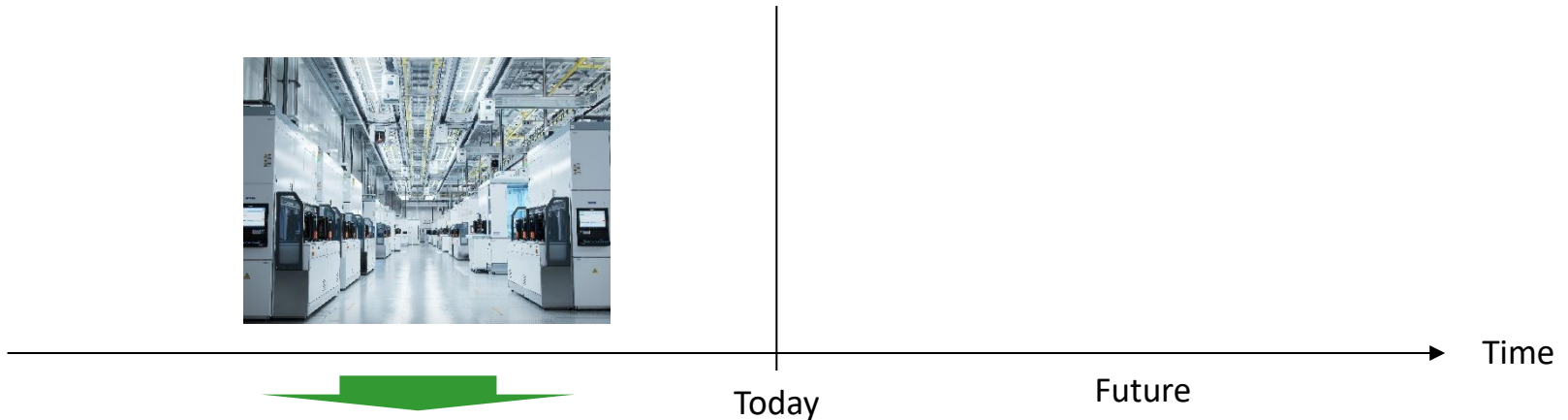

Learn from the Past!

Use of a Simulation Model

- Allows to significantly supplement the training data set with situations that have not appeared in historical data
- AI algorithm can experiment with decisions and their resulting impact which cannot be tested in the real factory



Past

Today



Time

Learn from the Future!

D-SIMCON AI Training Platform → Architecture

www.aissi-project.com

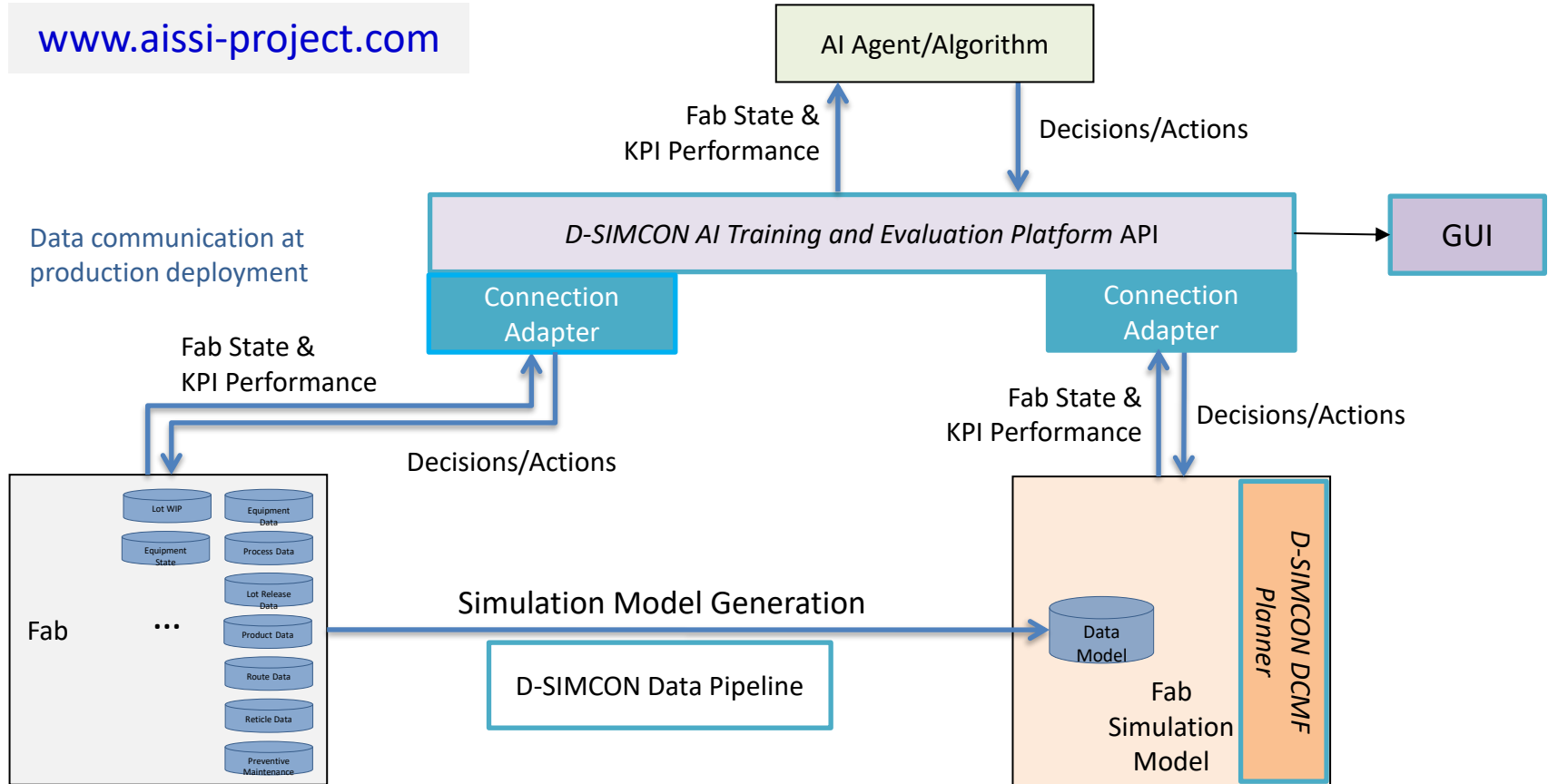

Overview

- (1) Semiconductor Manufacturing and Digital Twins
- (2) From Predictive to Prescriptive Operations Planning
- (3) Where AI comes into the picture
- (4) Integrated, Multi-Level D-SIMCON Digital Twin Suite

Business Planning: From Investment to Commitment

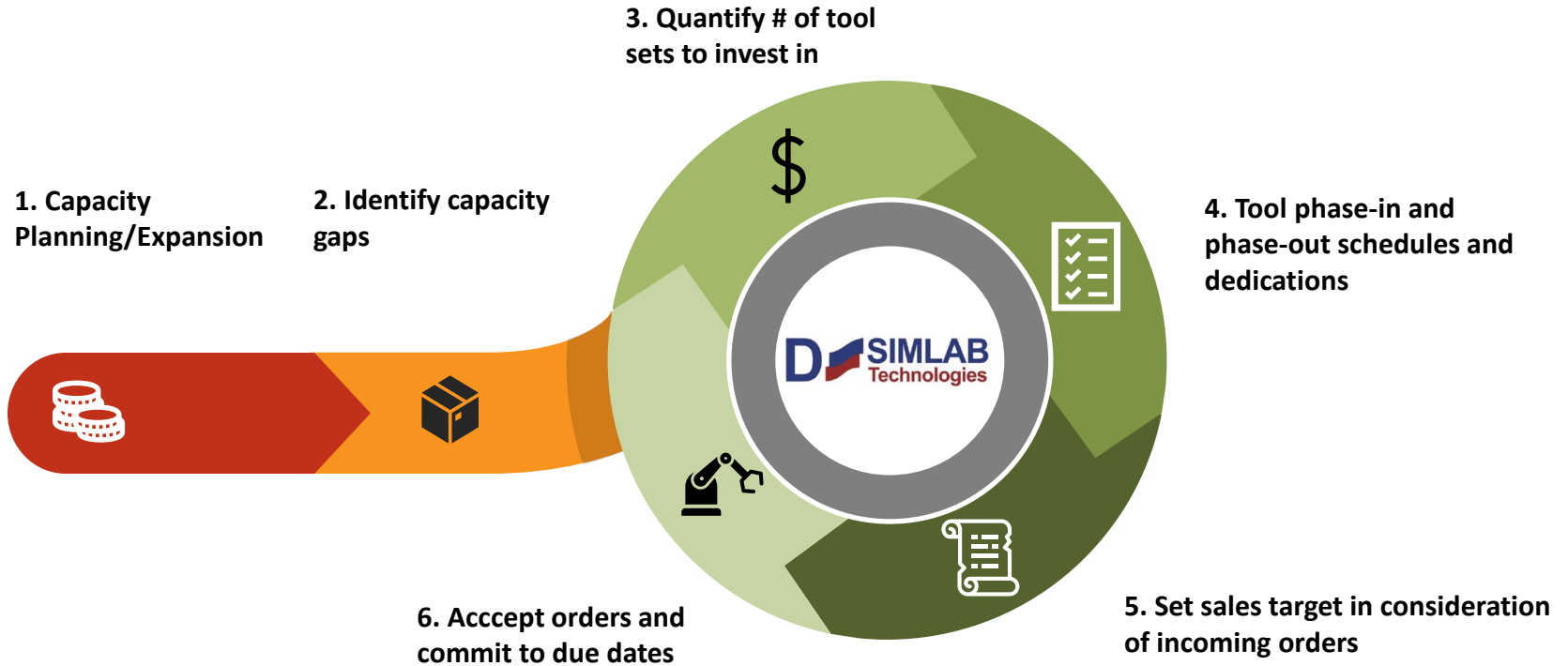

Dynamic Capacity Planning

High-fidelity simulation of dynamics of lots moving through the Fab and the allocation to tools operations

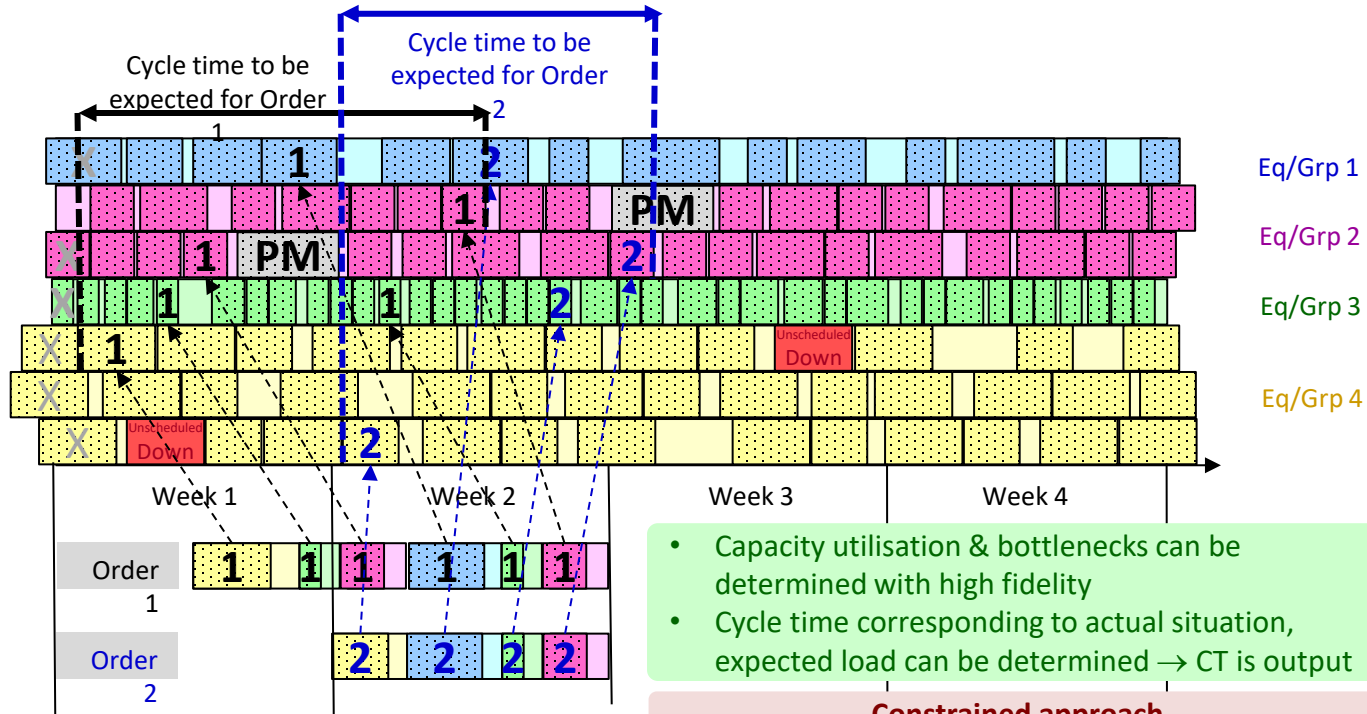

- Capacity utilisation & bottlenecks can be determined with high fidelity
- Cycle time corresponding to actual situation, expected load can be determined → CT is output

- Constrained approach**
- Validate investment requirement for tool purchases against cycle time

Static Capacity Planning

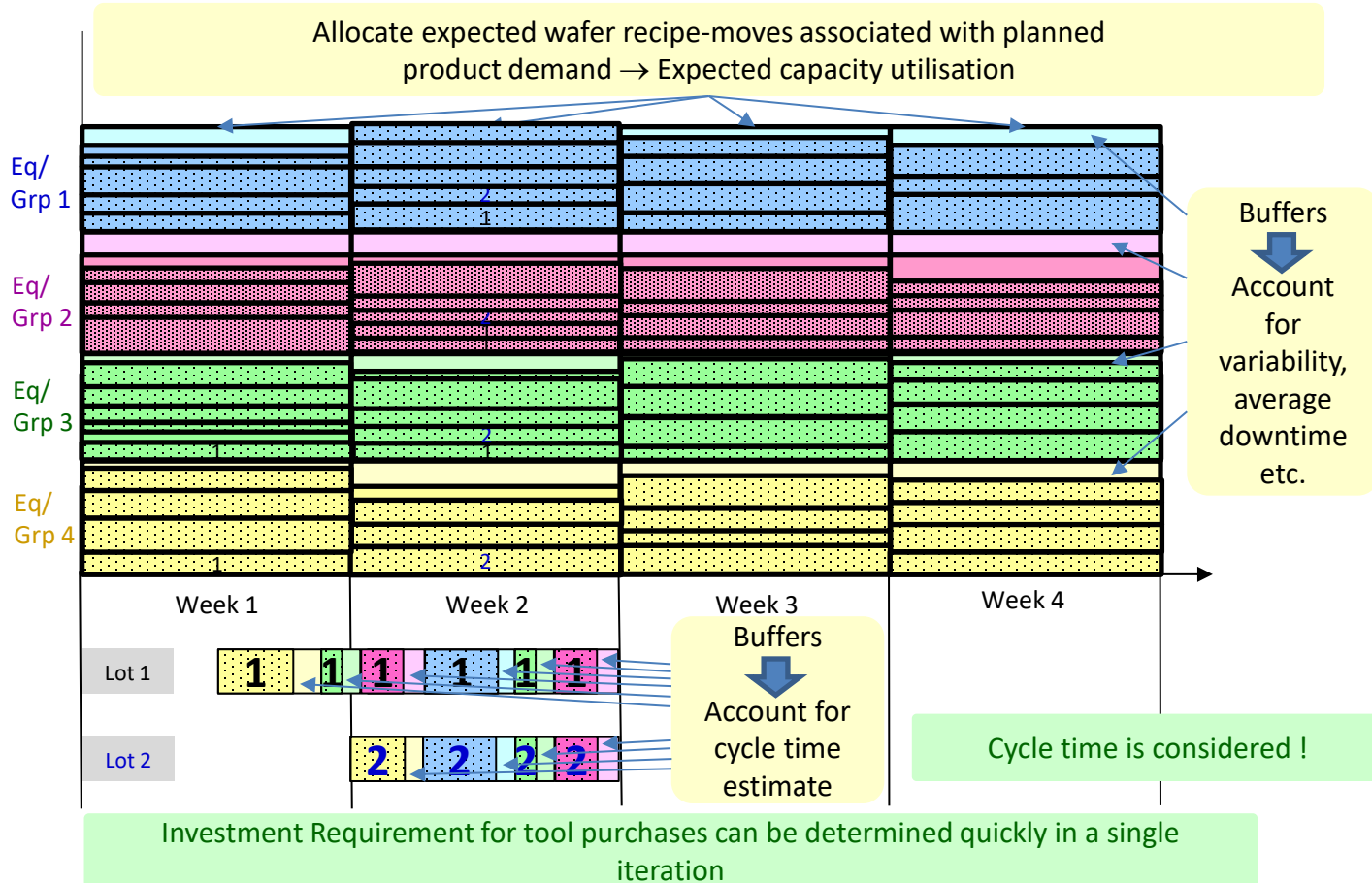

Load Mix Optimisation – Underlying Business Process

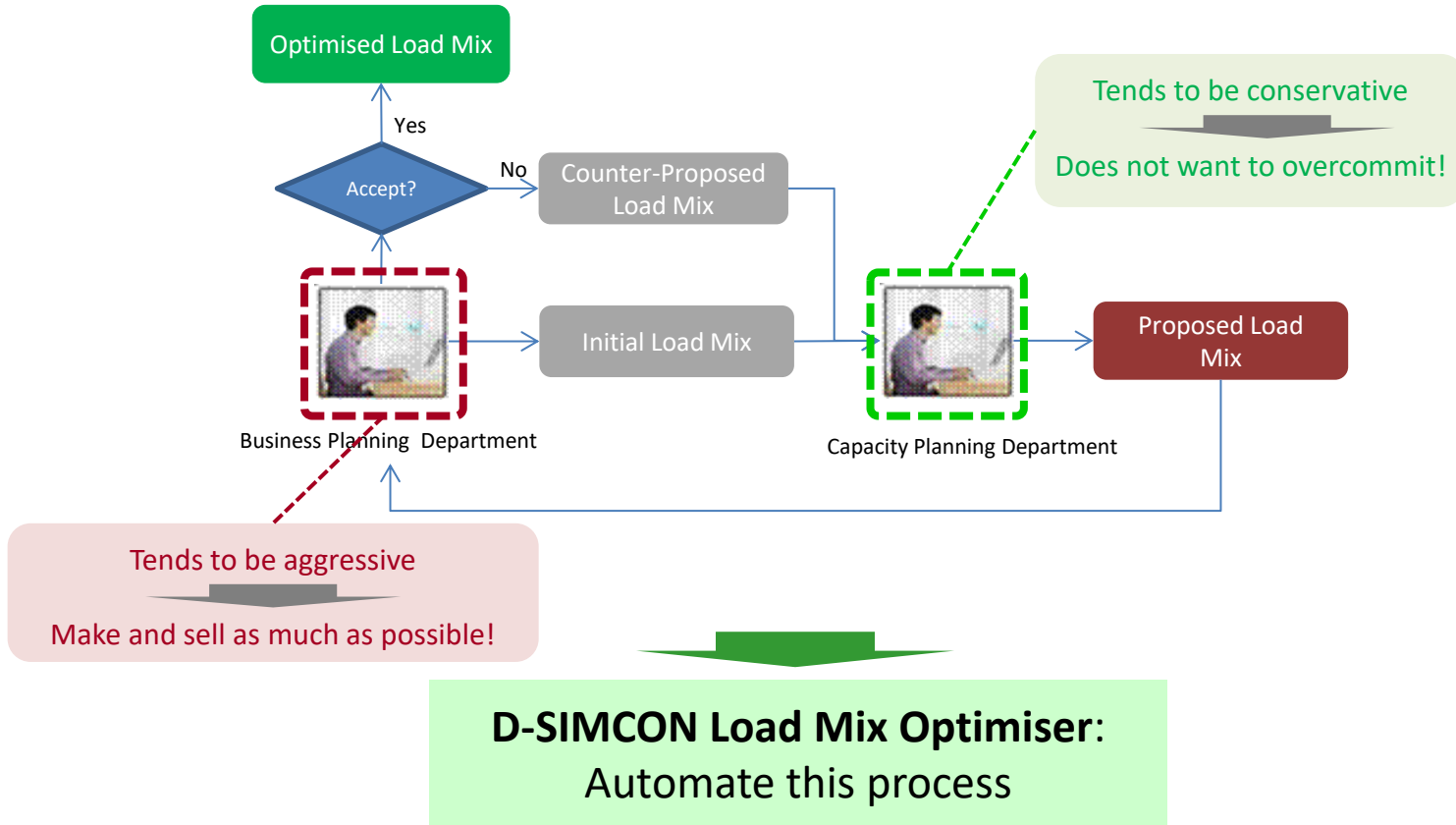

D-SIMCON Load Mix Optimiser – What it does...

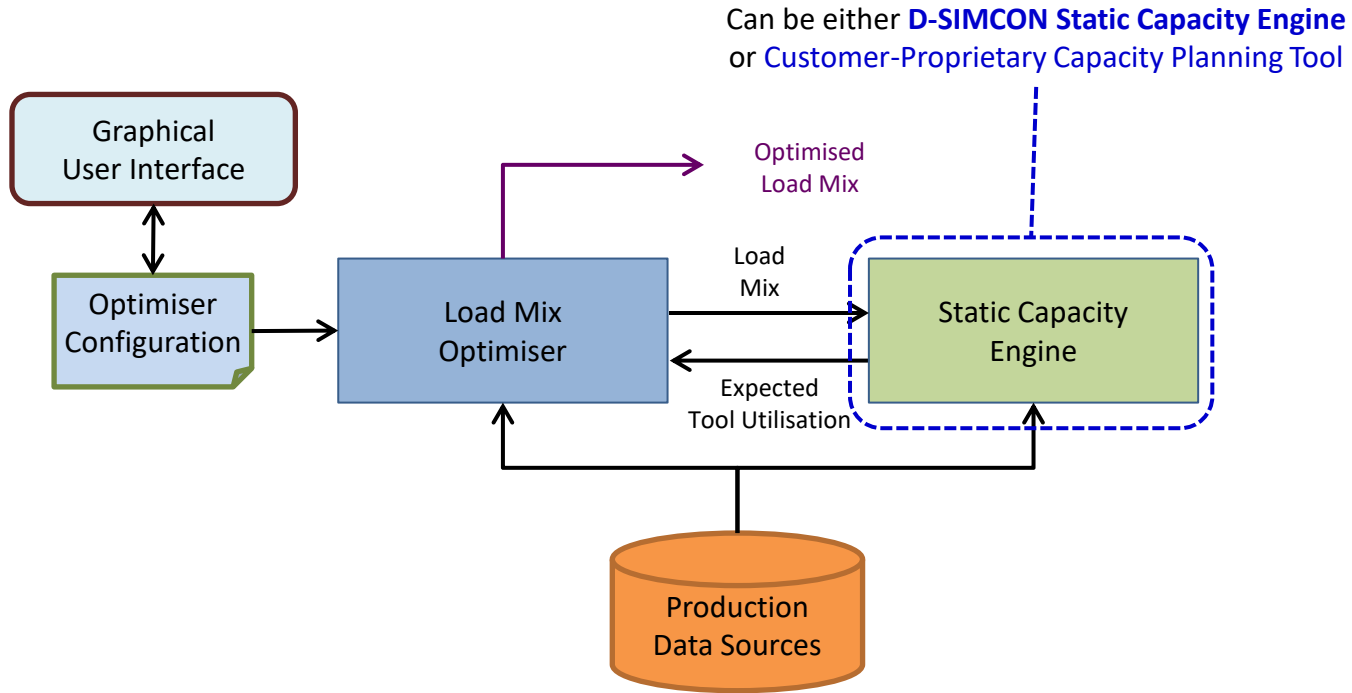

Example – D-SIMCON Load Mix Optimisation

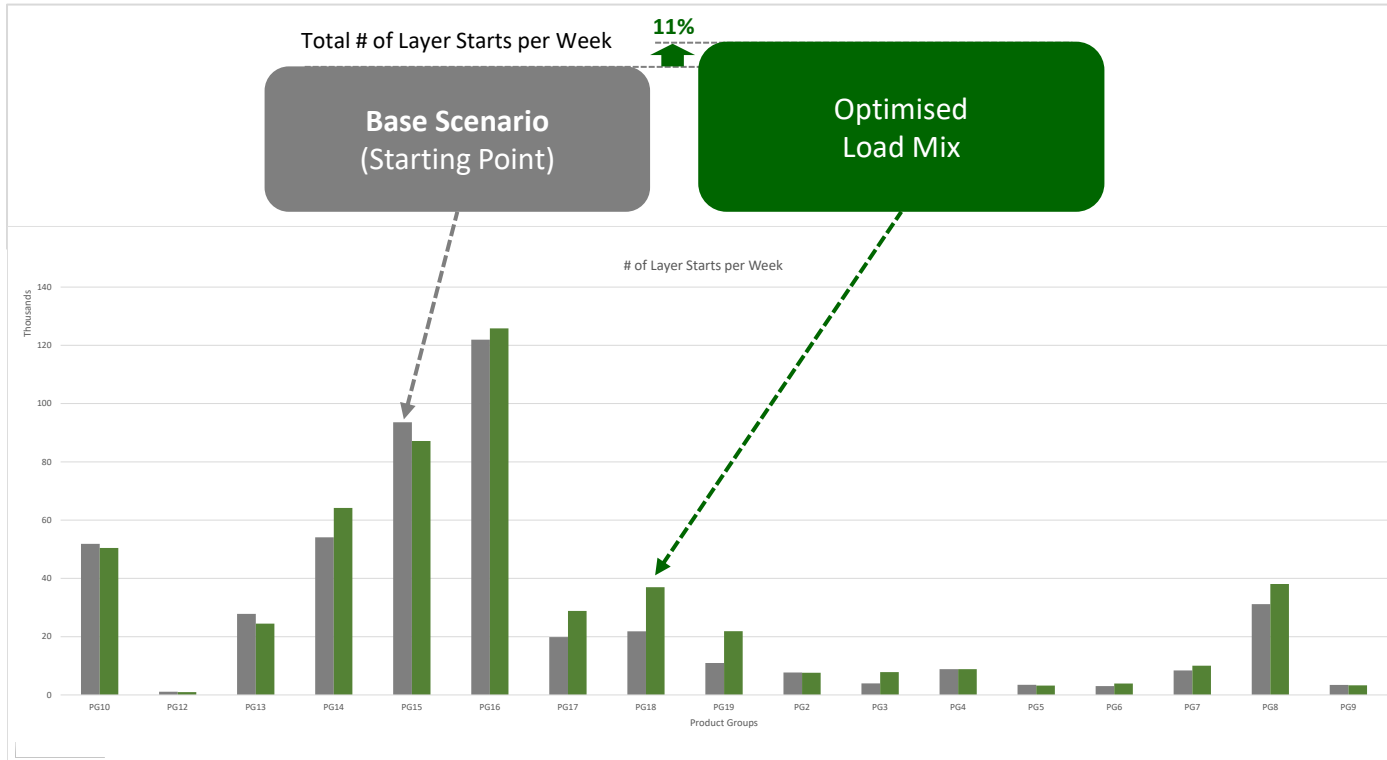

D-SIMCON Load Mix Optimiser – Benefits

Scenario	# of Equipment Groups		
	Close to utilisation limit [A]	Above utilisation limit [B]	High Utilisation [A]+[B]
Base	14	11	25
Optimised	20	0	20

No. of Equipment Groups requiring extra attention during operations reduced by 20%

Use DCMF Planner (Dynamic Simulation) to Validate Cycle Times

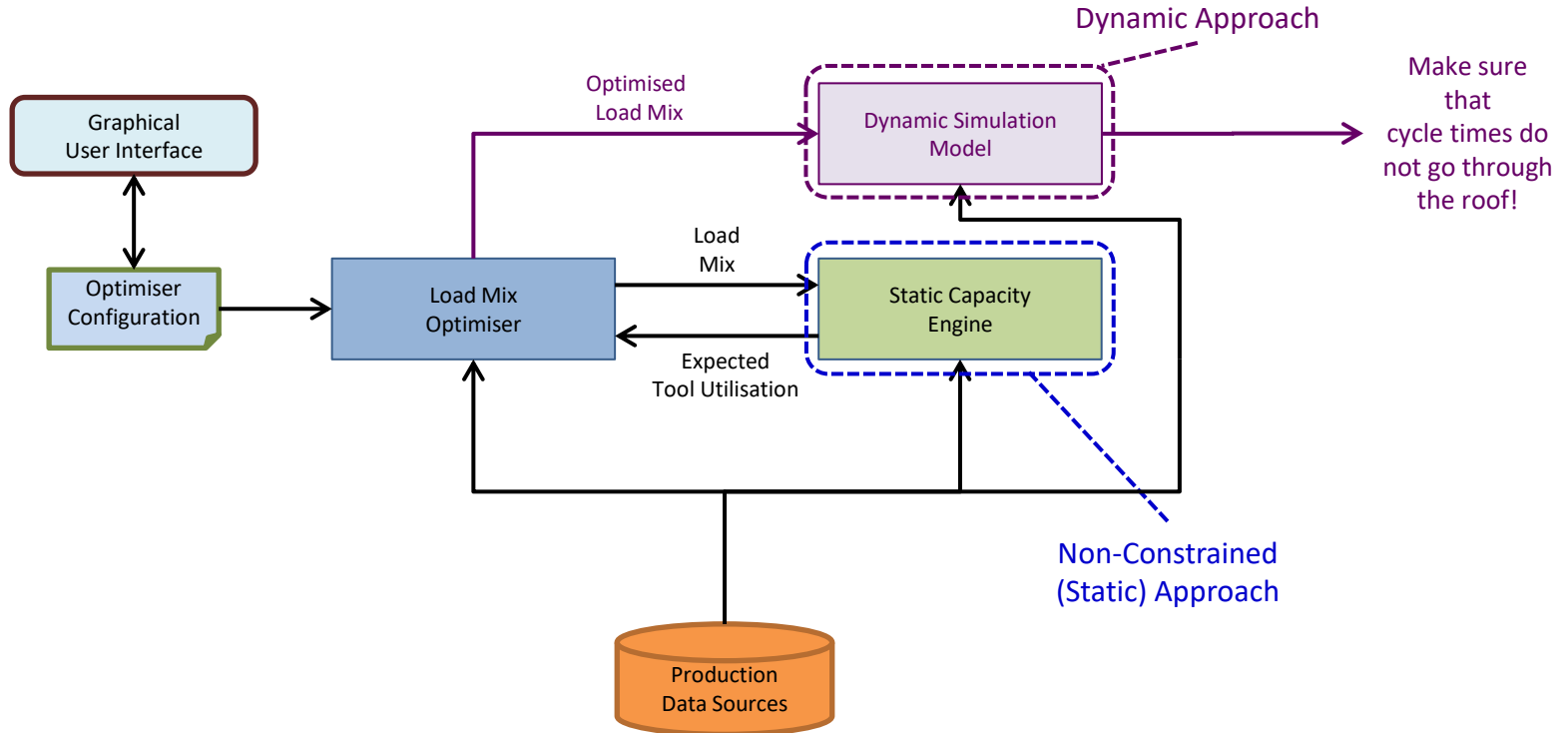

Validate Optimised Load Mix against CT Requirements with D-SIMCON DCMF Planner

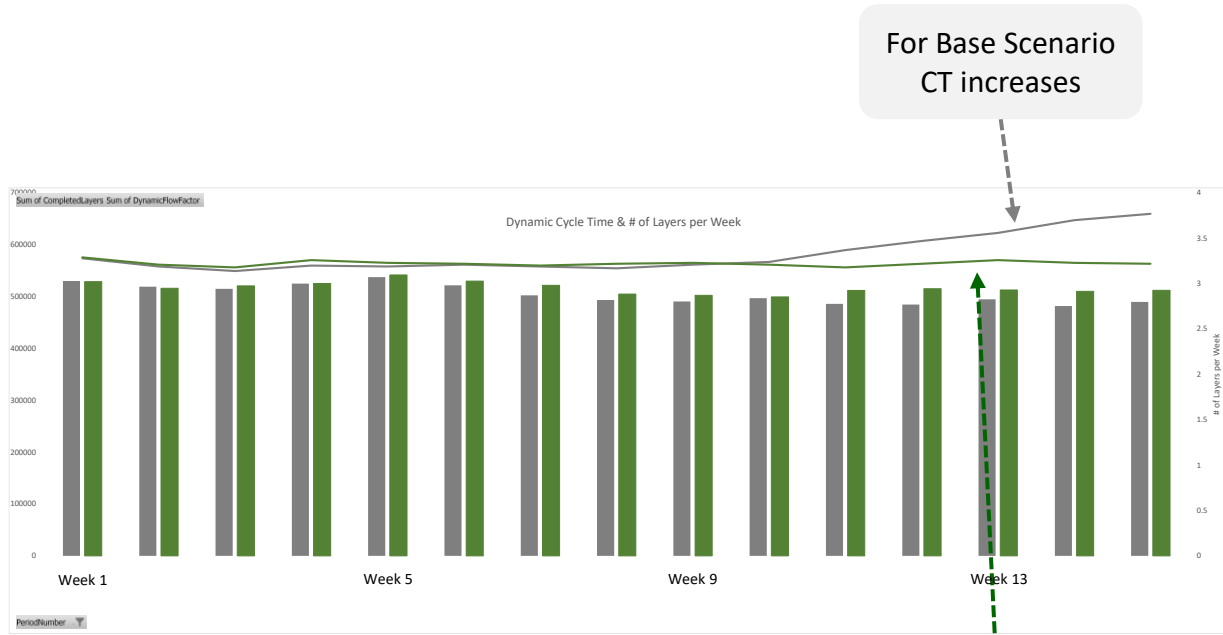

For Base Scenario
CT increases

Optimised Load
Mix Scenario is
stable all the way!

D-SIMCON Digital Twin & Optimisation Suite – Overview

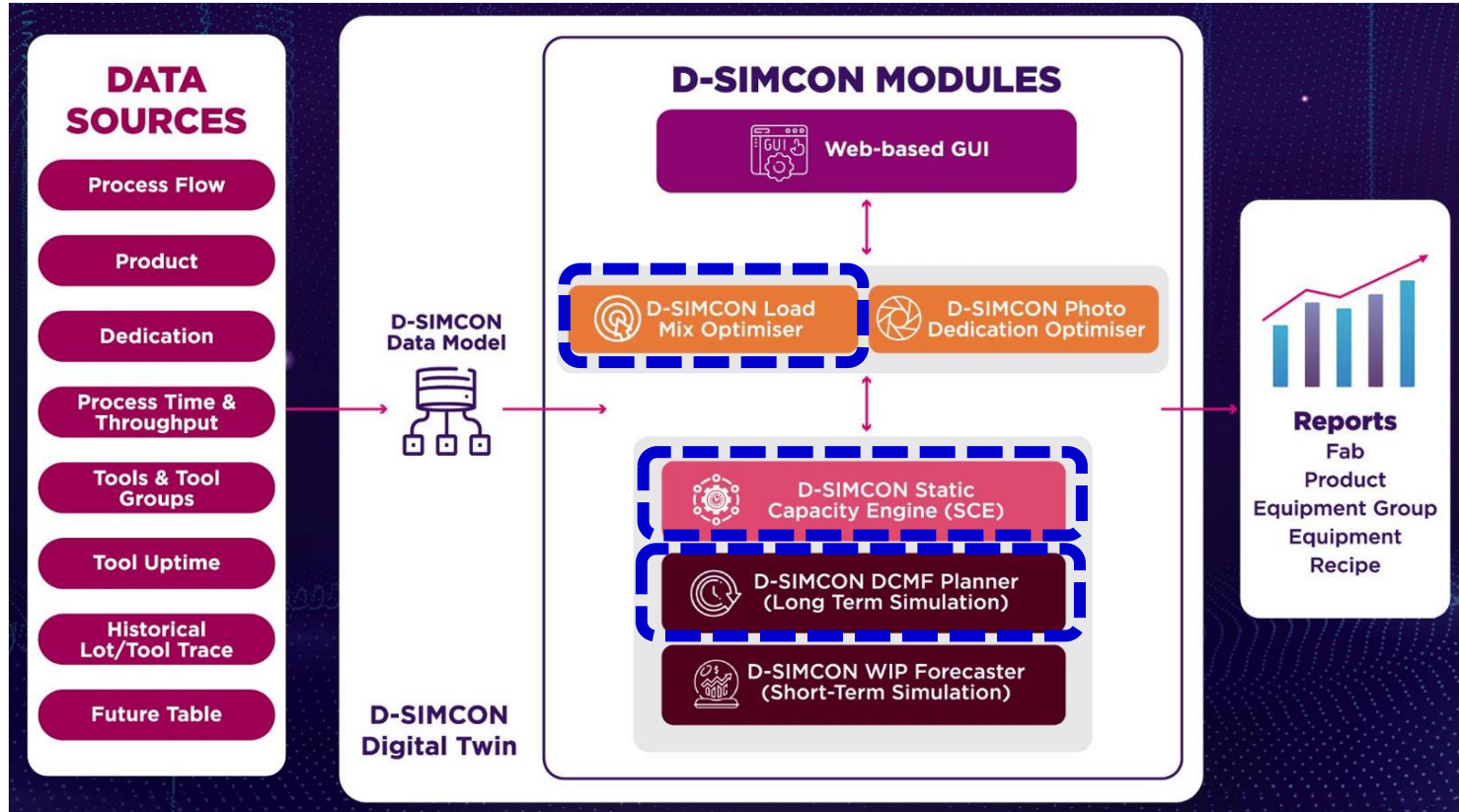

D-SIMCON Dynamic Capacity and Material Flow Performance Planner – Key Differentiators

- Many **wafer-fab specific** attributes can be portrayed
 - High accuracy KPI forecasts possible
- **Use case** based approach
- Supporting modules to **generate, calibrate and maintain with high degree of automation** the underlying simulation model
 - Resolution of data inconsistencies
 - Automatic Model Verification and Data Calibration
- **Unified Reporting Platform** for both Performance Monitoring and KPI Forecasting
- **Scalable** on High Performance (Cloud compliant) computing infrastructure
- **Site license model** for parallel execution of simulation runs

D-SIMCON Static Capacity Engine – Key Differentiators

- Many **wafer fab specific** constraints and equipment characteristics can be portrayed
 - Throughput dependency on the combination of products and even layers
 - Alternative recipe mapping
 - Route branching (machine load can be calculated accordingly)
 - Details of equipment **dedication** to recipes/products/steps can be portrayed
 - More **automated and systematic** way of capacity planning
 - Centralised and standardised input data with automatic base project generation
 - All planners work with the same base data
 - Easy adjustment of input data for what-if scenarios without having to modify base data
 - **Automatic balancing** of allocations across Equipment Groups
 - Extensive reporting, allowing to drill down to **high granularity** for easy comparison of different planning scenarios
- 
- Less error prone, more accurate and more realistic capacity planning

D-SIMCON Load Mix Optimiser – Key Differentiators

- Designed to work with the **D-SIMCON Static Capacity Engine**
 - ...but also works with other static capacity planning tools
- Multiple scenarios can be analysed **concurrently**
 - Leveraging multi-core capability, Cloud compliant
- **Many factors** that can be considered and adjusted
 - Tool utilisation limit %, financial factors, load ranges, non-financial considerations (such as priorities of certain customers) and weightages, customer priority ranking
- **Flexible** (configurable) objectives
 - Can maximise Wafers/Layers Out, Margin or Revenue
- Data **encryption**
 - Protect sensitive data such as sales prices and product costs

Semiconductor Mfg Customers

26 Fabs + 9 ongoing deployments

Europe, US, Japan, Taiwan, Southeast Asia

IDM, Foundry, Memory, LED

Fully automated, semi-automated, manually operated

Frontend (150/200mm, 300mm), Backend (A&T)

All customers have rolled out / are in the process of rolling out the D-SIMCON suite to **all their fabs worldwide**

Benefits Delivered

Load Mix Optimiser

13% higher wafer
start for available capacity
and tool mix

Static Capacity Engine

30% increase in
capacity planning accuracy
with **50% reduction**
in planning time

Photo Dedication Optimiser

5% increase
in photo capacity

DCMF Planner

12% increase
in output

WIP Forecaster

10% increase
in capacity



Peter Lendermann
Chief Business Development Officer
D-SIMLAB Technologies Pte Ltd

Email: peter@d-simlab.com

Website: www.d-simlab.com