

Keep It Simple & Save in Burn-In Operation

Joe Tan, Founder
MSV Systems & Services Pte Ltd
joetan@msv-asia.com

SEMICON[®] EUROPA

Nov 15-18, 2022 | MESSE



Content

1. Types of Burn-In Operation
2. Waste in Burn-In Operation
3. Root Cause of Waste
4. MudaX® - Introduction, Gains & Migration
5. Conclusion



Types of Burn-In Operation



Manual Burn-In Operation

Manual Oven + Manual BLU (MO+MB)

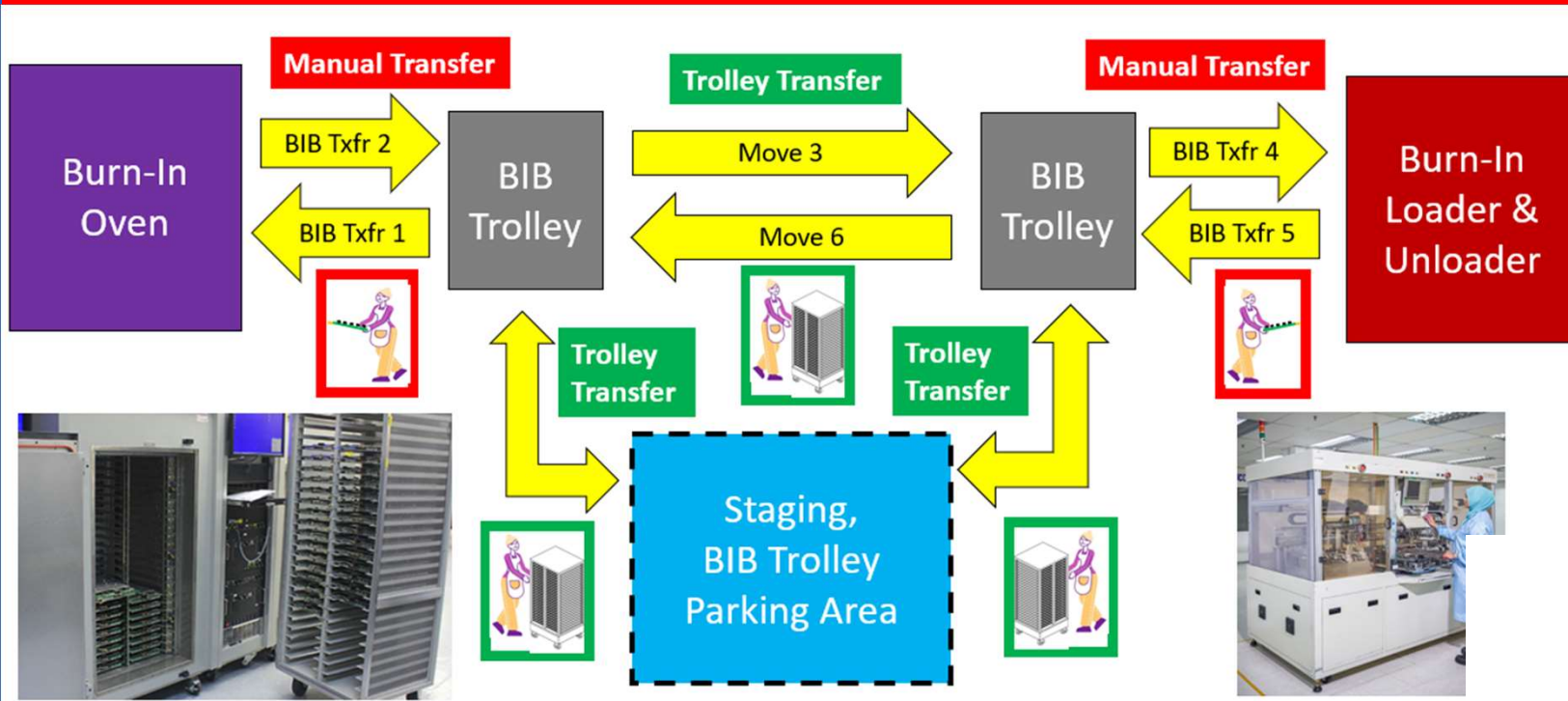

Hybrid Burn-In Operation

Manual Oven + Trolley BLU (MO+TB)

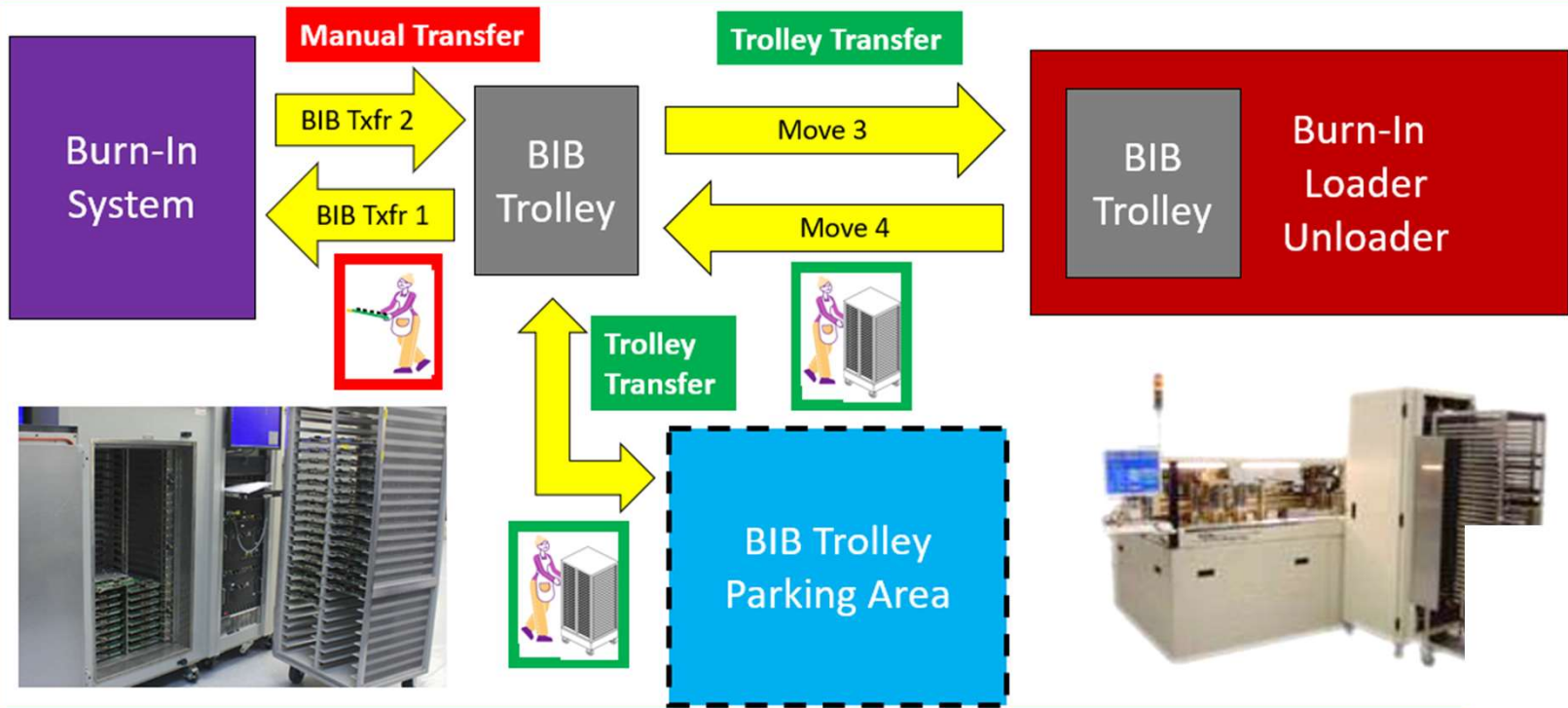

Rack Burn-In Operation

Rack Oven + Rack BLU (RO+RB)

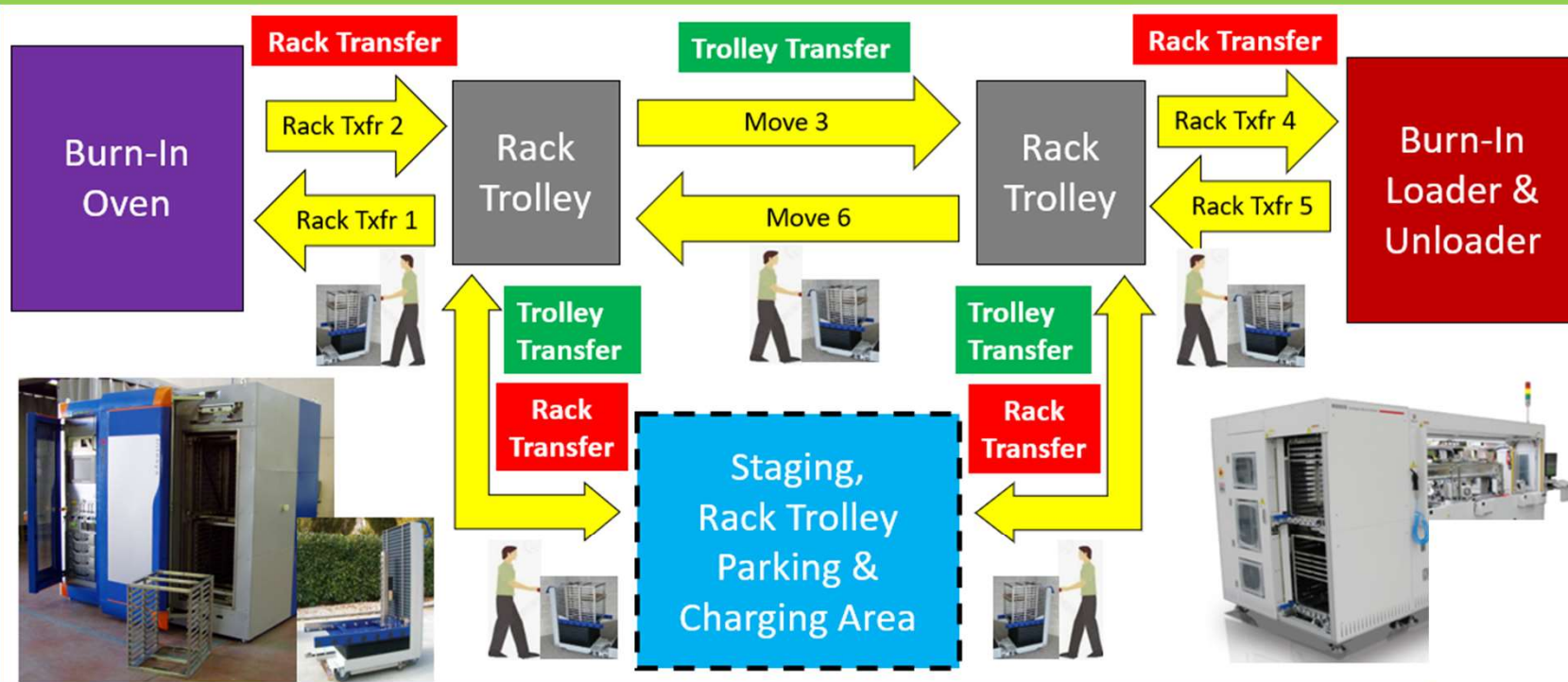

Waste in Burn-In Operations

SEMICON® EUROPA
Nov 15-18, 2022 | MESSE

© MSV-JT220918



Waste #1: Time

1. Excessive Manual Transfer

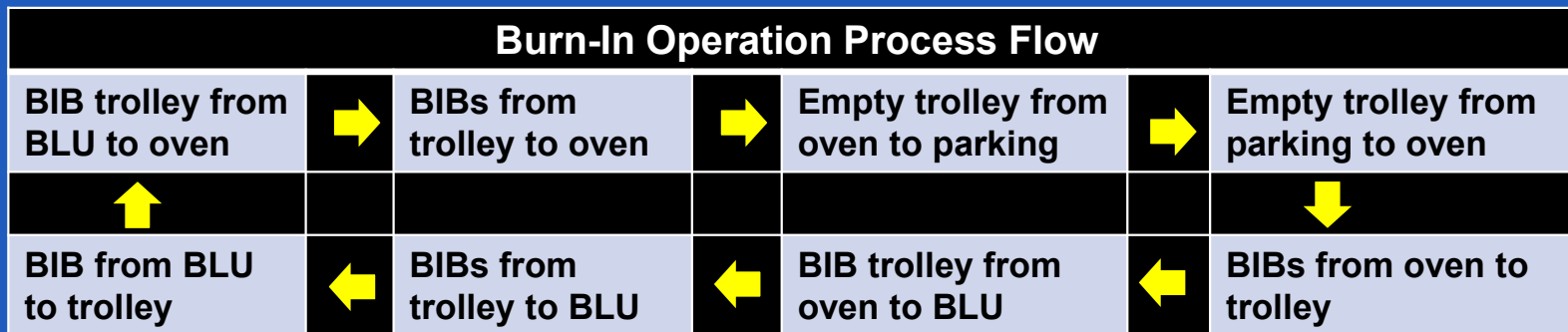

2. Locating Burn-In Board

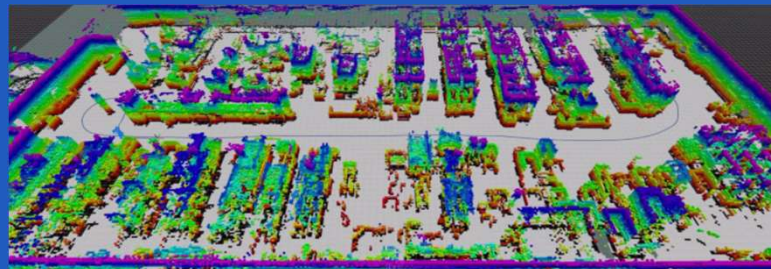

Waste #2: Space

1. Parking Space for Empty Trolley & Damaged Boards
2. Wide Space for Rack Operation & Automation



Waste #3: Money

1. High Maintenance Cost for Recurring Damage
2. High Automation Cost with Little Efficiency Gain



Root Cause of Waste

SEMICON® EUROPA
Nov 15-18, 2022 | MESSE

© MSV-JT220918



Root Cause #1: Gap in Integration

- Lack of, or Imperfect Integration
- Uneven Floor = Docking Difficulty



Root Cause #2: Human Fatigue

- Excessive Manual BIB Transfer
- Cascading Damage in Production



Excessive Manual
BIB Transfer



Equipment Damage



$\eta \downarrow$ OEE \downarrow Cycle Time \uparrow



Root Cause #3 : BIB Tracking Problem

- Inability to Track Damaged BIBs
- Unable to Stop Cascading Damage



Inability to Track BIB

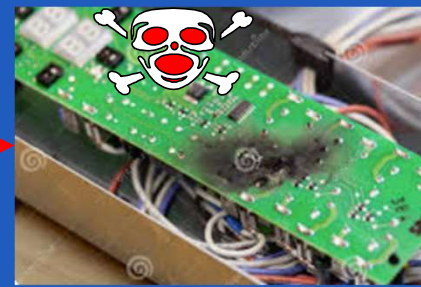
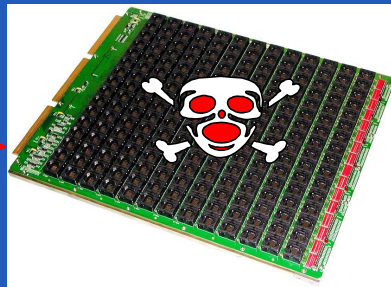

MudaX® Introduction

SEMICON® EUROPA
Nov 15-18, 2022 | MESSE

© MSV-JT220918



MudaX® = ~~Muda~~ = ~~Waste~~

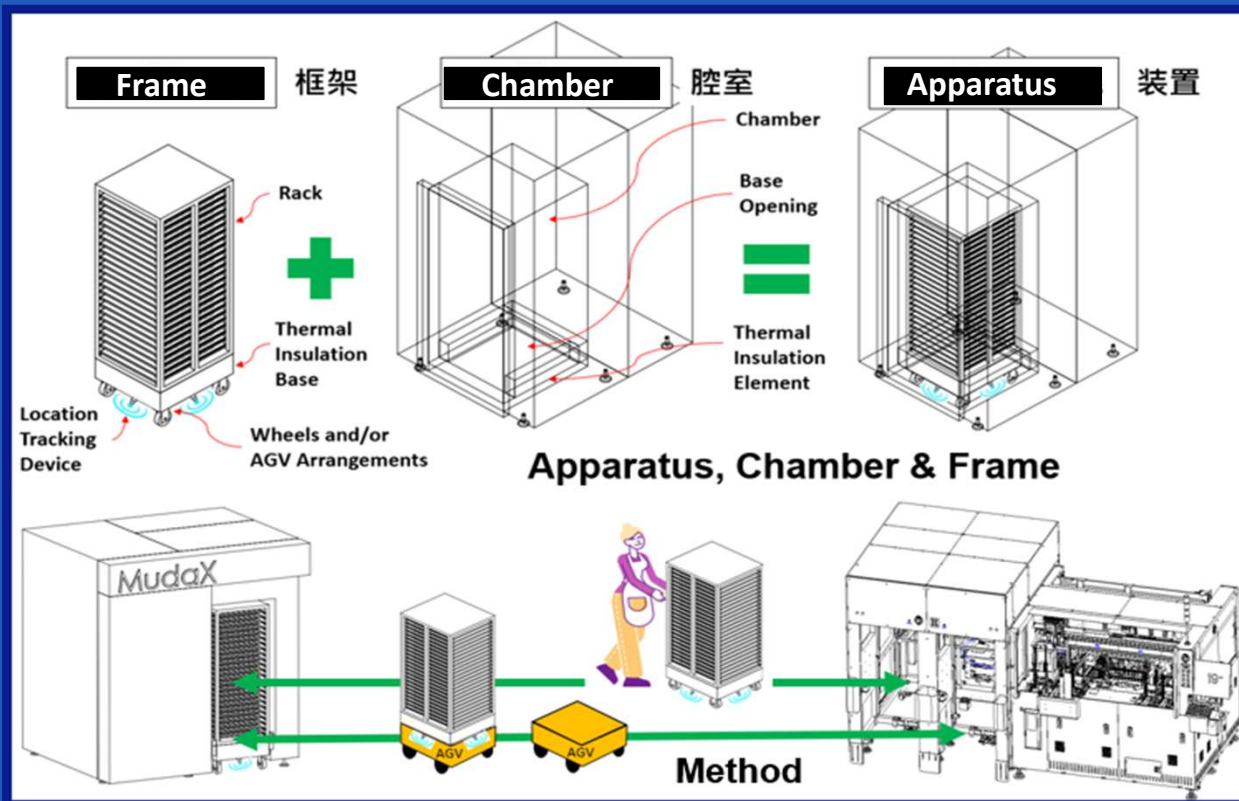

Direct Frame/Trolley Docking Chamber & Transfer Method



Frame, Chamber & Apparatus

Frame



Chamber



Apparatus



Transfer Method

Trolley from Oven → *Trolley to BLU* → *Trolley from BLU* → *Trolley to Oven*



MudaX® Gains

SEMICON® EUROPA
Nov 15-18, 2022 | MESSE

© MSV-JT220918



Gain #1: Simple Integration

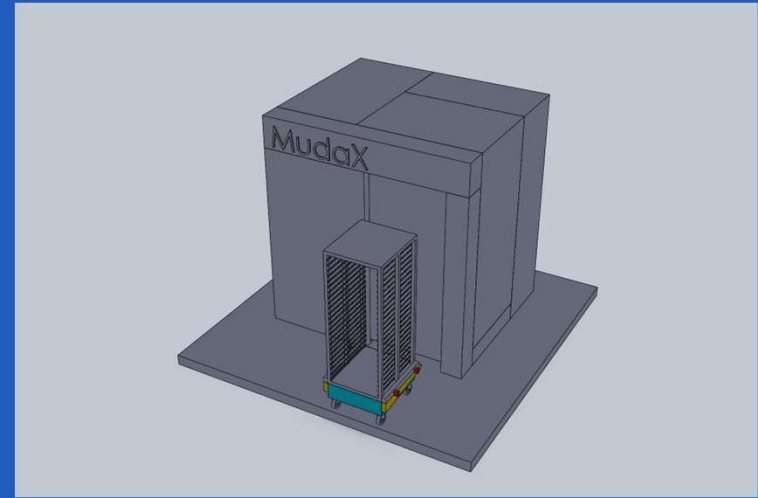
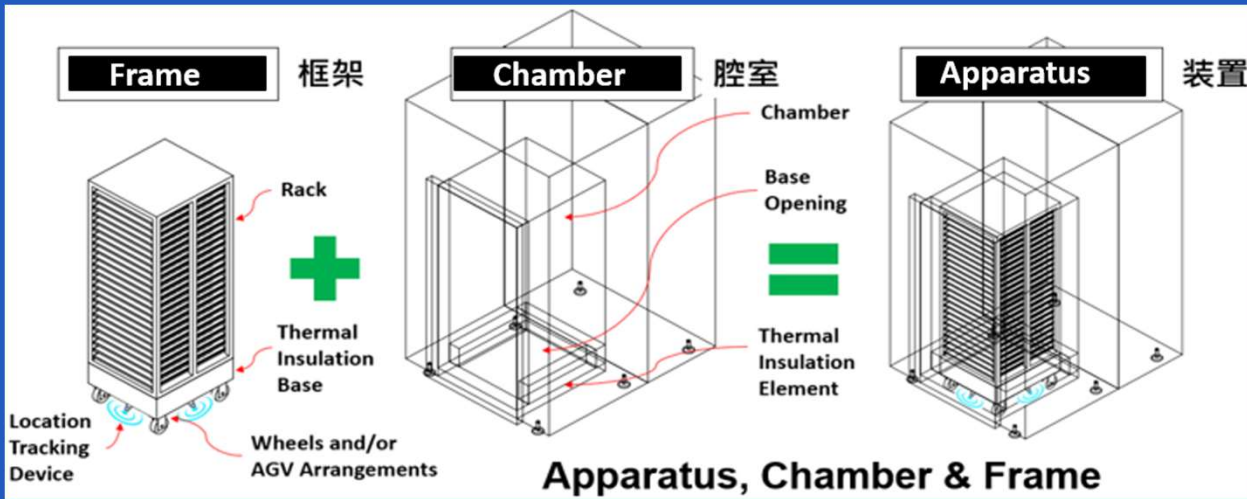

- Frame
- Chamber
- Apparatus
- Method



- Alignment
- Sealing



Gain #2 : Eliminate Human Fatigue

| Burn-In Operation Process Flow | | | | | |
|------------------------------------|---|--------------------------------------|---|---|---|
| BIB trolley from BLU to oven | ➔ | BIBs from trolley to oven | | Empty trolley from oven to parking | Empty trolley from parking to oven |
| BIB from BLU to trolley | | BIBs from trolley to BLU | ➔ | BIB trolley from oven to BLU | BIBs from oven to trolley |

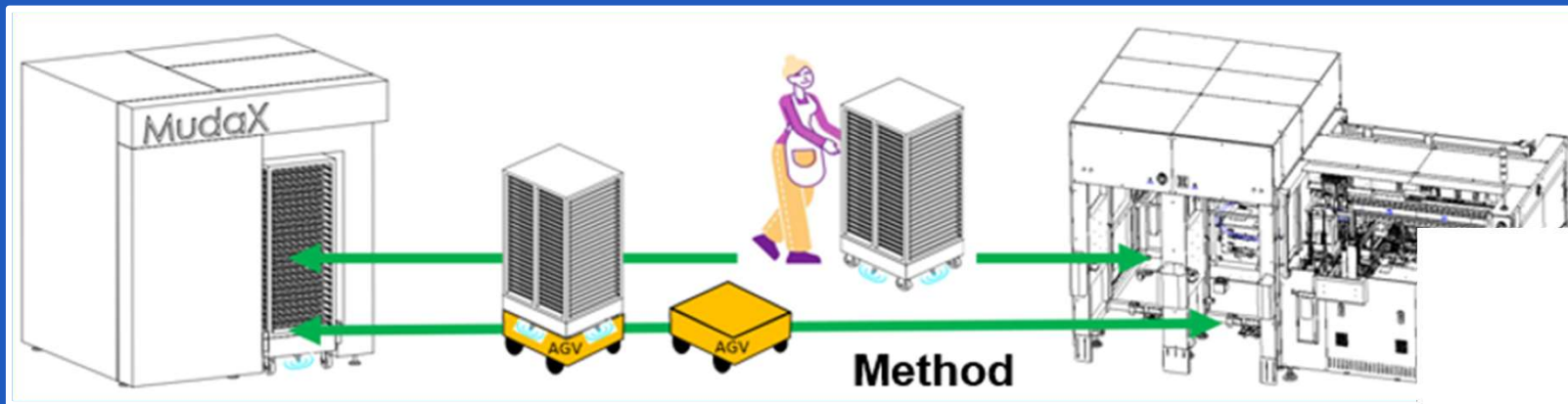

Gain #3: Simple BIB Tracking

- BIBs Always in Frame
- Tracking Device is Mounted Under Frame & Out of Thermal Zone
- Tracking Frame = Tracking BIBs = Stopping Damages

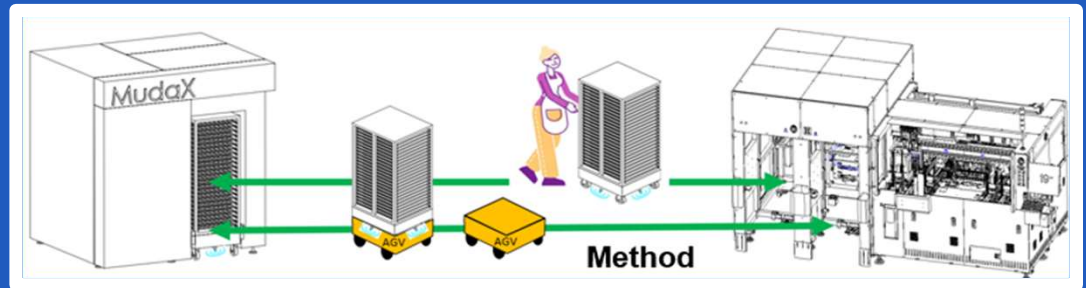

Process Simulation Model

- Based on 1 BLU, 6 Oven, 7 Frame

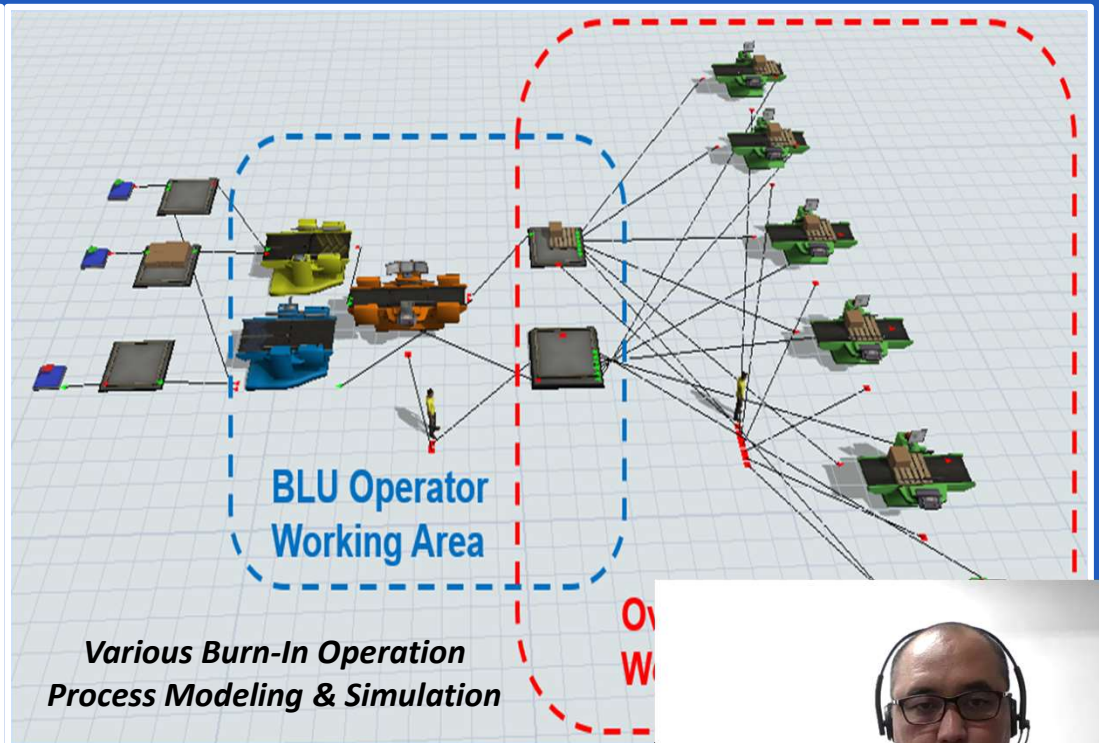
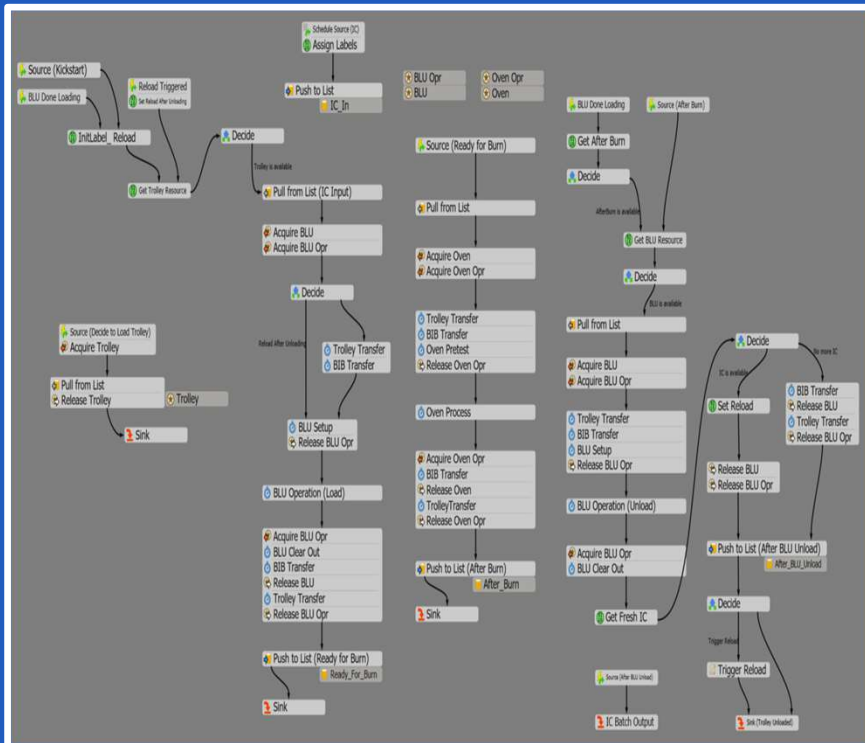

Various Burn-In Operation
Process Modeling & Simulation



Process Simulation Result

- Based on 1 BLU, 6 Oven, 7 Frame

With Exact Same Resources, MudaX vs Other Process

| | | | |
|---|-------------------------------|--------------|---------------|
| 1 | Burn-In Cycles | ▲ Up to 6.0% | |
| 2 | Throughput | ▲ Up to 7.1% | |
| 3 | Throughput Lost Due to Damage | | ▼ Up to 1.0% |
| 4 | BLU Max Possible Utilization | ▲ Up to 8.5% | |
| 5 | BLU Overall Utilization | | ▼ Up to 5.5% |
| 6 | Oven Overall Utilization | ▲ Up to 5.5% | |
| 7 | BLU Operator Utilization | | ▼ Up to 27.4% |
| 8 | Oven Operator Utilization | | ▼ Up to 33.1% |



MudaX® Migration

SEMICON® EUROPA
Nov 15-18, 2022 | MESSE

© MSV-JT220918



Migrating to MudaX - BLU

- No Change to Existing BLU or Operation
- Next BLU to be MudaX-Ready (Frame Handling)
- Upgrade Existing BLU if Ok (Reuse BLU Main Body)



Migrating to MudaX – Burn-In System

- No Change to Existing Burn-In System or Operation
- Next System to be MudaX-Ready (Frame Docking)
- Reuse System (Driver, FTC, PS) with New Chamber

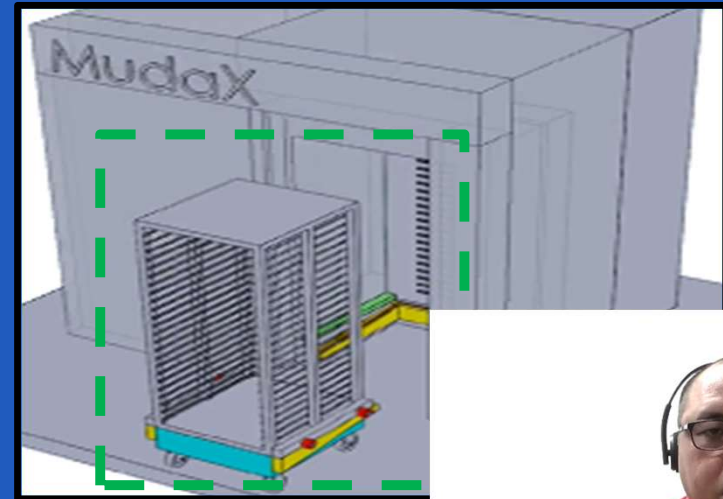
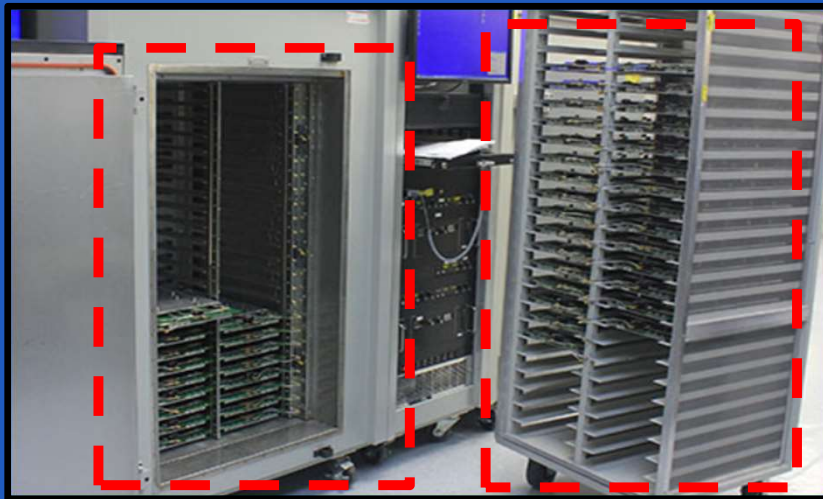

Migrating to MudaX – Frame Transfer

- No Change to Existing Burn-In Operation
- Hybrid Transfer with Human and AGV / AMR
- Eventual Full AGV / AMR Automation (Lights Off)



Conclusion



Keep It Simple & Save

- ✓ Time
- ✓ Space
- ✓ Money

Through
MudaX®

