

Organizational Chart

- Europe
- Japan
- Korea
- North America
- Taiwan

Last updated: November 21, 2011

SEMI Europe Regional Standards Organization

Co-chairs: Jean-Marie Collard - Solvay Chemicals, Werner Bergholz - Jacobs University of Bremen

Compound Semiconductor Materials Committee

C: A. Weber - SiCrystal

EHS Committee

C: B. Planting - ASML
C: T. Pilz – Pilz Automation

Photovoltaic Committee

C: L. Fabry - Wacker Chemie
C: H. Aulich - PV Crystalox Solar

Equipment Automation Committee

C: A. Honold - InReCon (I&C, PIC, Metrics)
C: M. Carrubba - Numonyx (I&C, PIC)
C: L. Pfitzner - FhG IISB (Metrics)
VC: F. Petzold - Trustsec (I&C)

Gas & Liquid Chemicals Committee

C: J-M Collard - Solvay Chemicals
C: G. Ferrier - Air Products
VC: G. De Vos - FFEM

Photovoltaic Automation Committee

C: T. Körner - Q-Cells
C: M. Zenning - Jonas & Redmann
C: E. Teichmann - Peer Group

Silicon Wafer Committee

C: W. Bergholz - Jacobs University of Bremen
C: P. Wagner - Consultant

SEMI Europe EHS, Equipment Automation, and Gas & Liquid Chemicals Committees

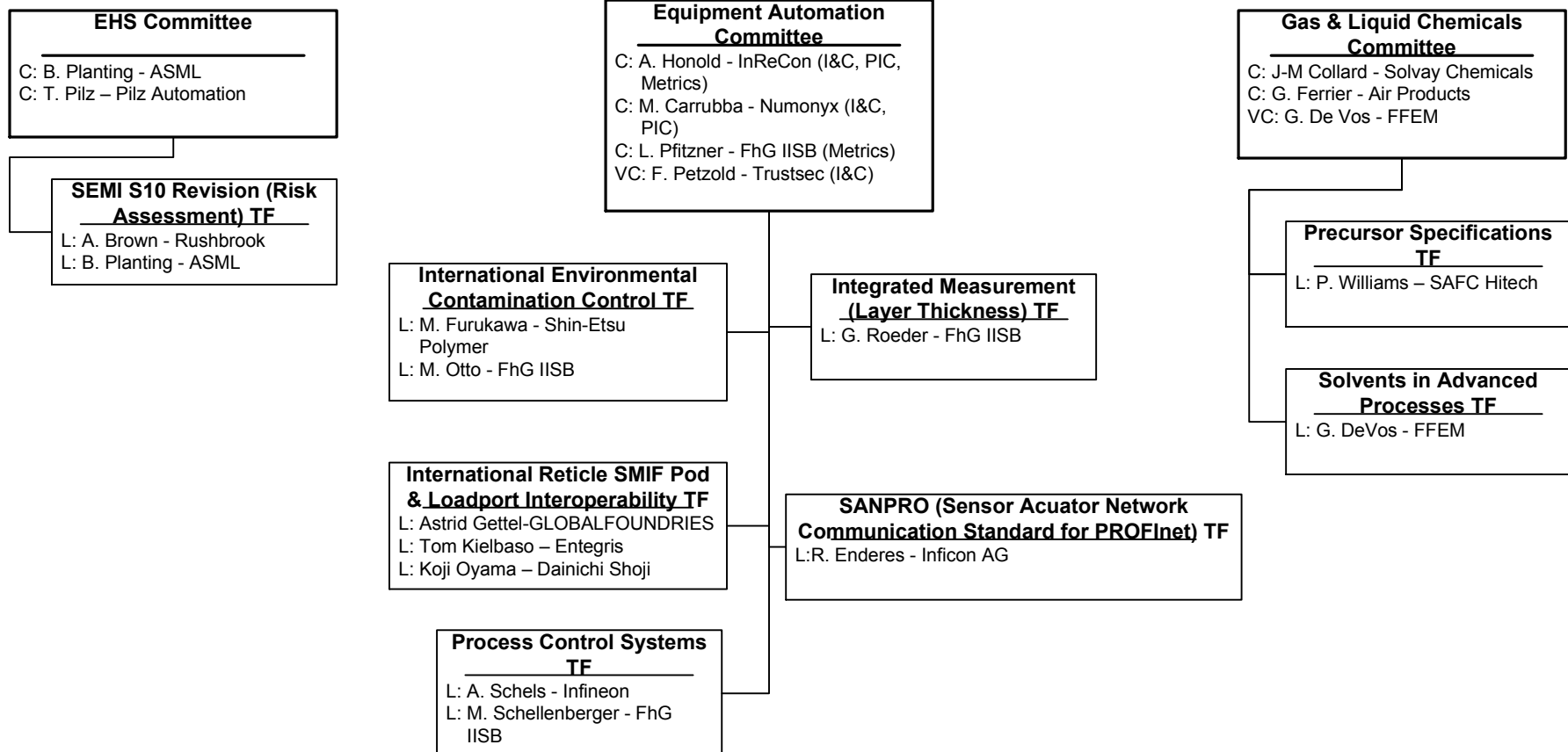

SEMI Europe PV, PV Automation, Compound Semiconductor and Silicon Wafer Committees

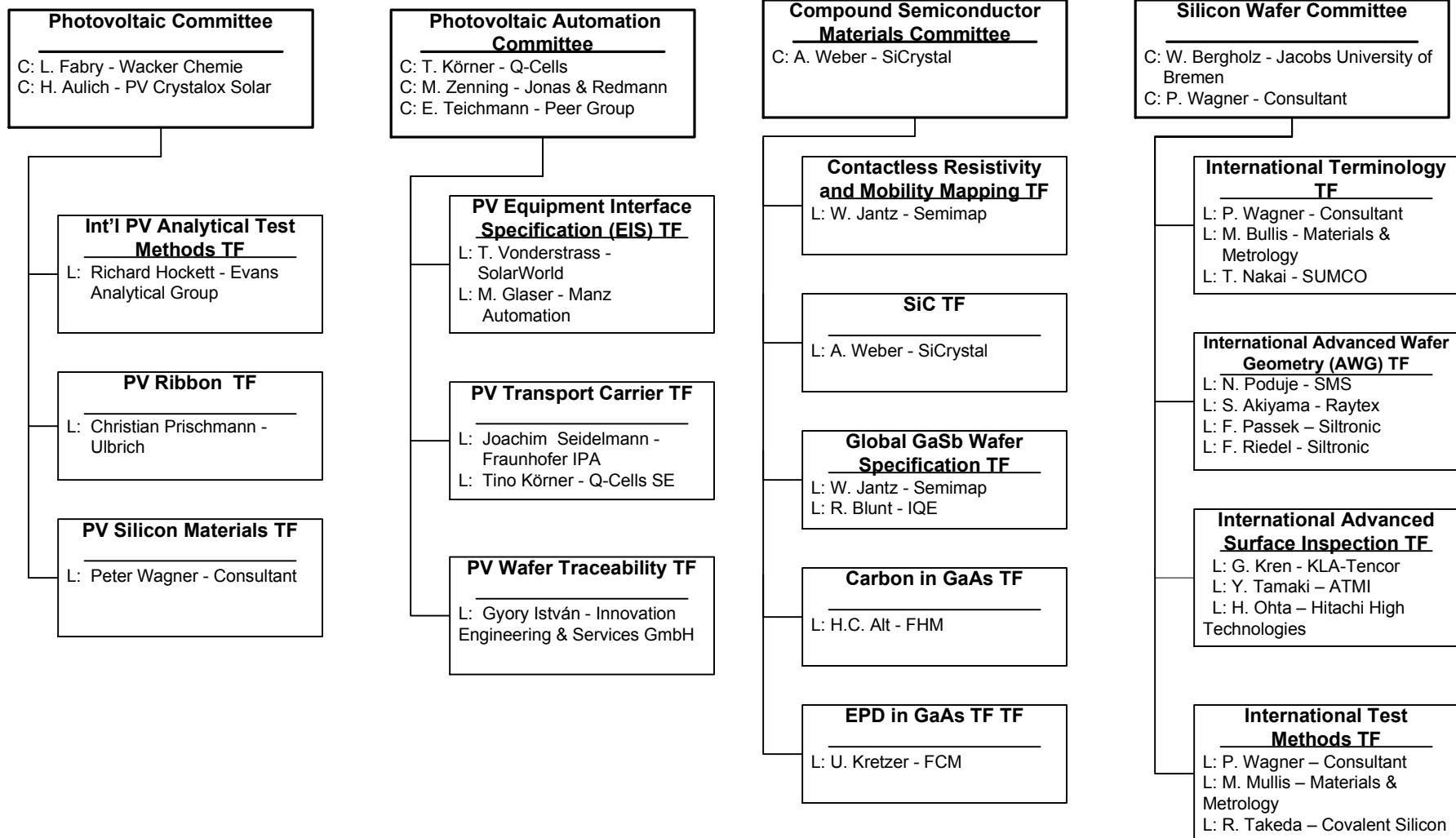

SEMI Japan Regional Standards Organization

Co-Chair: Shigeru Kobayashi - Renesas Technology Co-Chair: Makoto Yamamoto - Muratec Automation
Vice Chair: Supika Mashiro - TEL

Information & Control Committee

C: Takayuki Nishimura - DNS
C: Mitsutoshi Matsuda - Hidachi Kokusai Electric
VC: Takehiko Ishikawa - TEL

Photovoltaic Materials Committee

C: Takashi Ishihara - Mitsubishi Electric
C: Kazuhiko Kashima - Covalent Materials
C: Masaaki Yamamichi - AIST

Test Committee

C: Hirofumi Kaga - Renesas Electronics
C: Takashi Umenaga - Teradyne

FPD Factory Automation Committee

C: Yasunobu Otagawa - Daihen
C: Harumichi Hirose - Shibaura Mechatronics

Physical Interfaces & Carriers Committee

C: Shoji Komatsu - Acteon
C: Tsuyoshi Nagashima - Miraial
C: Tsutomu Okabe - TDK

Photovoltaic Committee

C: Hiromu Takatsuka - Mitsubishi Heavy Industries
C: Kazuhiko Kashima - Covalent Materials
C: Masaaki Yamamichi - AIST
C: Terry Asakawa - TEL

Environmental Health & Safety Committee

C: Hidetoshi Sakura - Intel
C: Supika Mashiro - TEL
C: Moray Crawford - Hatsuta Selsakusho

FPD Materials & Components Committee

C: Hisashi Aruga - Seiko Epson
C: Tadaihiro Furukawa - Kyodo Printing
C: Yoshihiko Shibahara - FUJIFILM

Metrics Committee

C: Toshio Murakami - Murakami Corporation
C: Mikio Furukawa - Shin-Etsu Polymer

Photovoltaic Automation Committee

C: Terry Asakawa - TEL
C: Emi Ishikawa - Atelier Ishikawa

Gases & Facilities Committee

C: Hiromichi Enami - Hitachi High-Technologies
C: Isao Suzuki - MKS Japan

FPD Mask Committee

C: Atsushi Okazaki - SK-Electronics
C: Kaname Nitobe - HOYA

Micropatterning Committee

C: Iwao Higashikawa - Toshiba

Liquid Chemicals Committee

C: Hiroshi Tomita - Toshiba
C: Kenji Sugimoto - DNS

Compound Semiconductor Materials Committee

C: Masayoshi Obara - SEH
C: TBD

FPD Metrology Committee

C: Ryoichi Watanabe - Toshiba Mobile Display
C: Yuji Yoda - Otsuka Electronics

Traceability Committee

C: Michio Honma - Renesas Electronics
C: Hirokazu Tsunobuchi - Keyence

Packaging Committee

C: Kazunori Kato - AiT
C: Haruo Tabata - Osaka University
C: Yutaka Koma - Advisor

Silicon Wafer Committee

C: Naoyuki Kawai - University of Tokyo
C: Tetsuya Nakai - SUMCO

Special Groups

Reporting to the JRSC

Standardization Process Integration (SPI)

L: Supika Mahiro - TEL

FPD Coordination Group

L: Yoshitada Nogami - SK Electronics
L: Makoto Yamamoto - Muratec

SEMI Japan PV, PV Materials, and PV Automation Committees

**Photovoltaic Materials
Committee**

C: Takashi Ishihara - Mitsubishi
Electric
C: Kazuhiko Kashima - Covalent
Materials
C: Masaaki Yamamichi - AIST

Japan PV Materials TF

L: Masaaki Yamamichi - AIST
L: Takashi Ishihara -
Mitsubishi Electronic

**Photovoltaic Automation
Committee**

C: Emi Ishikawa - Atelier Ishikawa
C: Terry Asakawa - TEL

**Global PV Equipment Interface
Specification (PV-EIS) TF**

L: Takashi Murakami - TEL
L: Makoto Ishikawa - Nisshinbo
Mechatronics

**PV Transport Carrier
TF**

L: Koji Ohyama - Dainichi Shoji
L: Shuichi Inoue - Miraial

Photovoltaic Committee

C: Hiromu Takatsuka - Mitsubishi
Heavy Industries
C: Kazuhiko Kashima - Covalent
Materials
C: Masaaki Yamamichi - AIST
C: Terry Asakawa - TEL

PV Safety SG

L: Yasuhiro Yamauchi -
Mitsubishi Heavy Industries

SEMI Japan PI&C and Metrics Committees

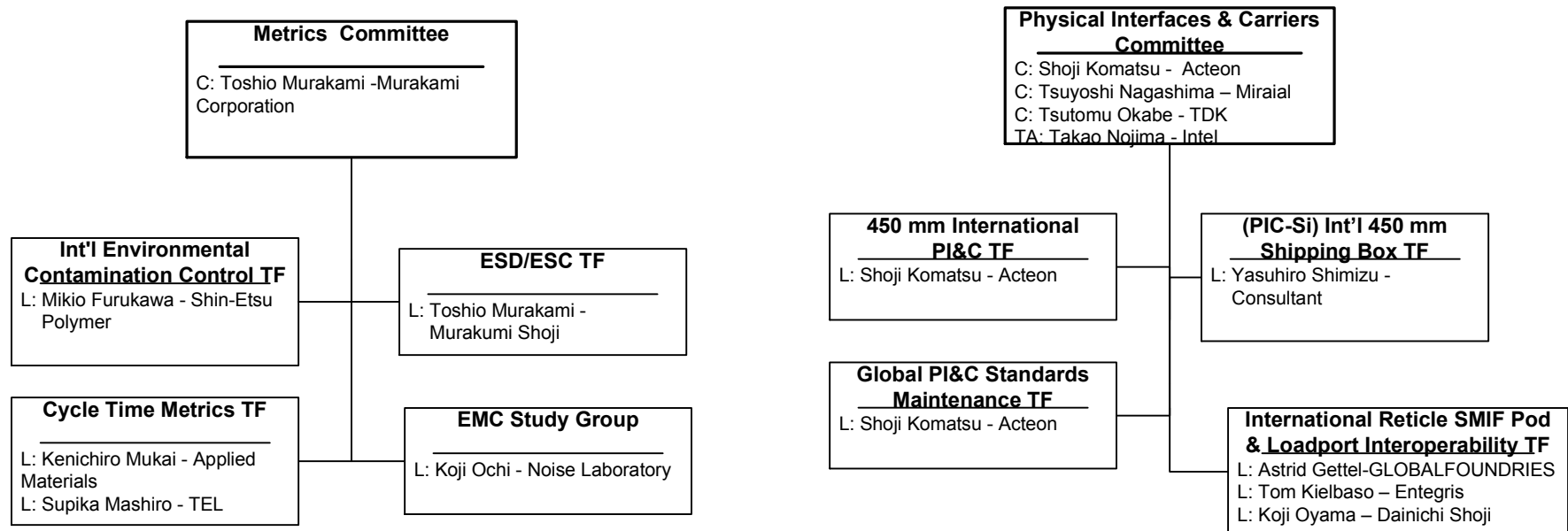

SEMI Japan Information & Control, and Traceability Committees

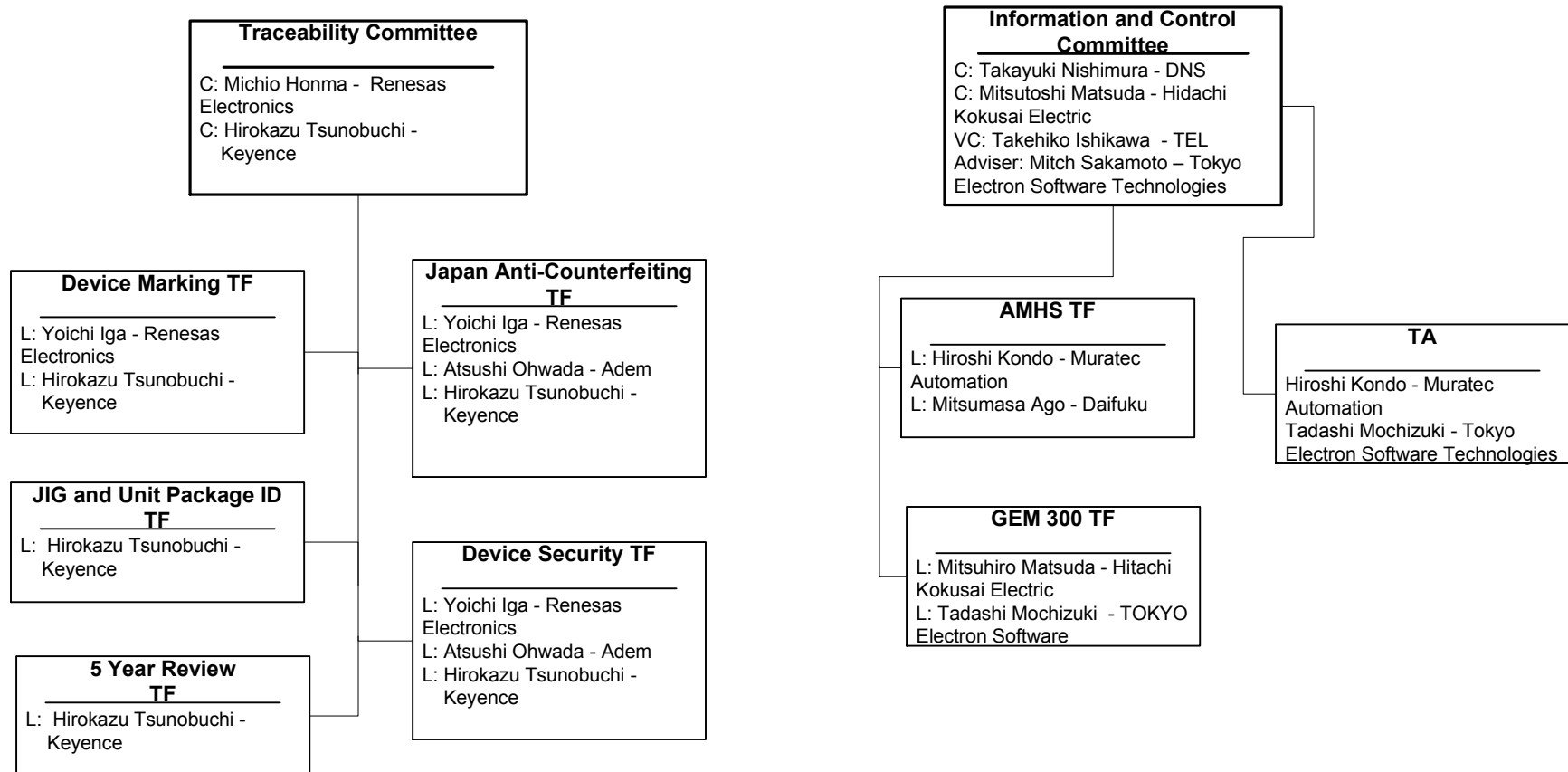

SEMI Japan Gases & Facilities, and Liquid Chemicals Committees

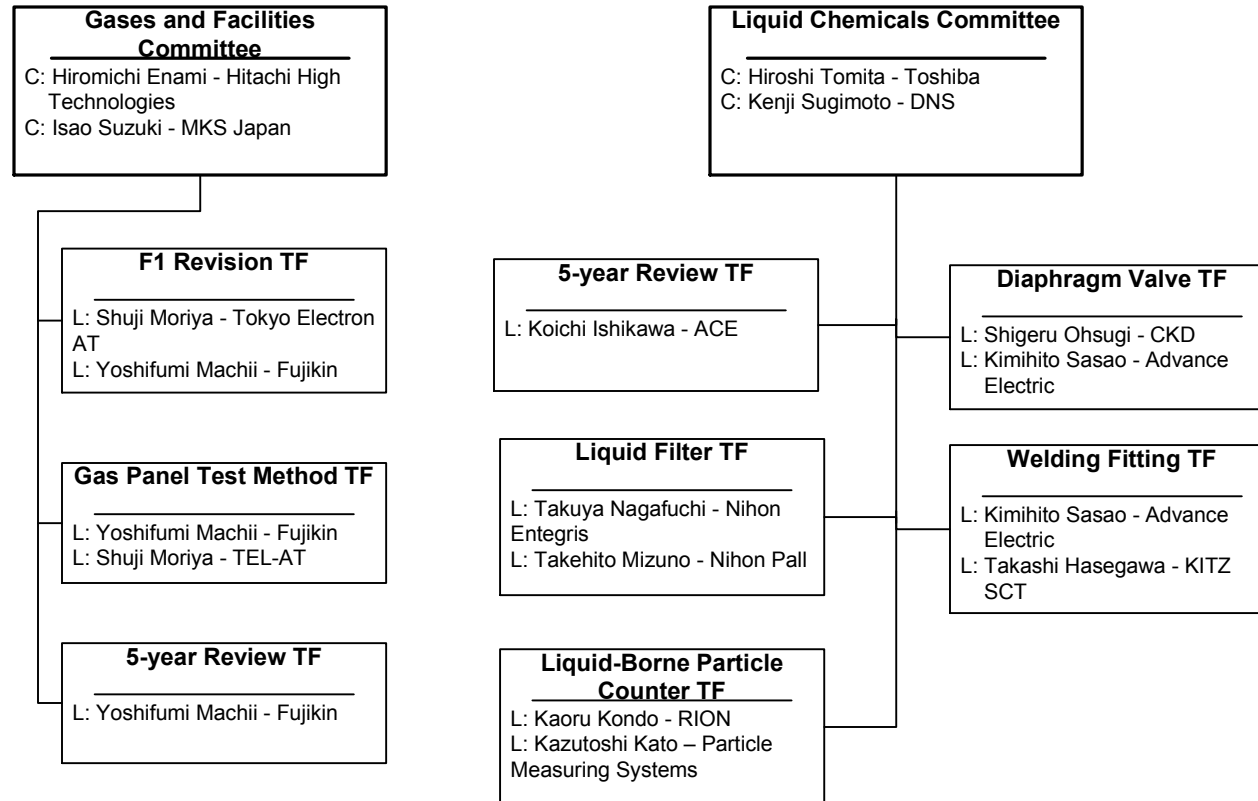

SEMI Japan EHS Committee

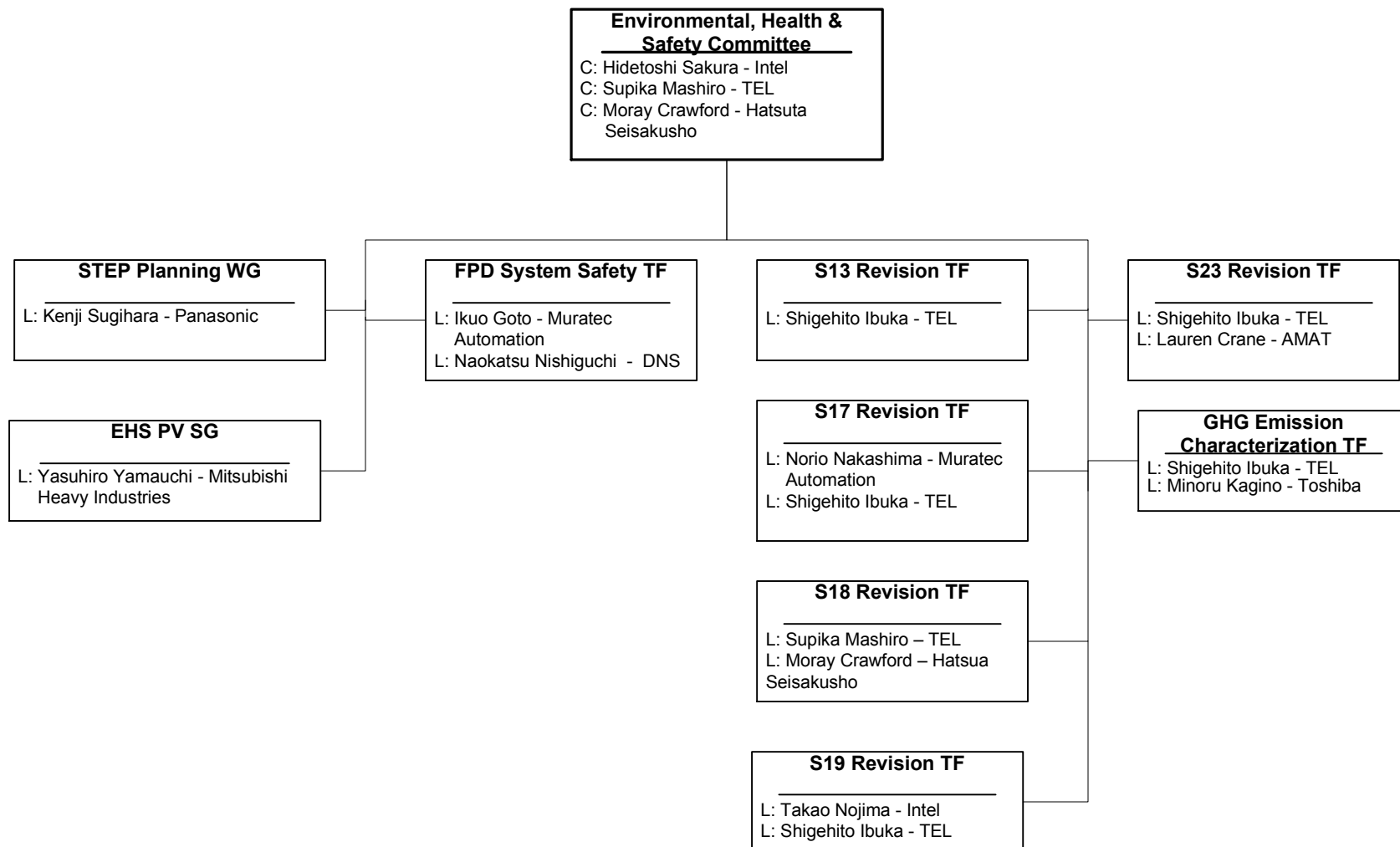

SEMI Japan FPD Factory Automation, Materials & Components, Mask, and Metrology Committees

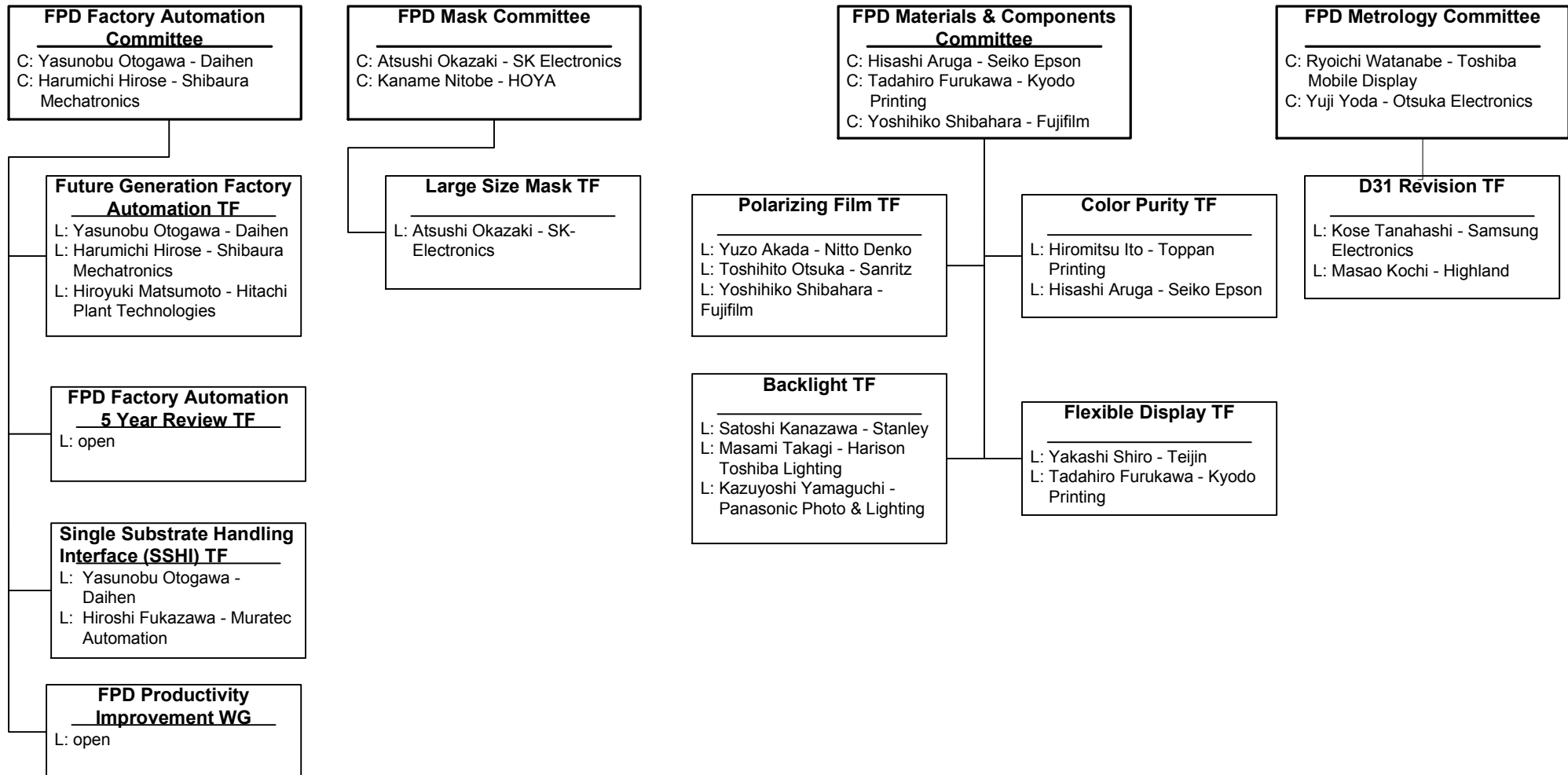

SEMI Japan Silicon Wafer Committee

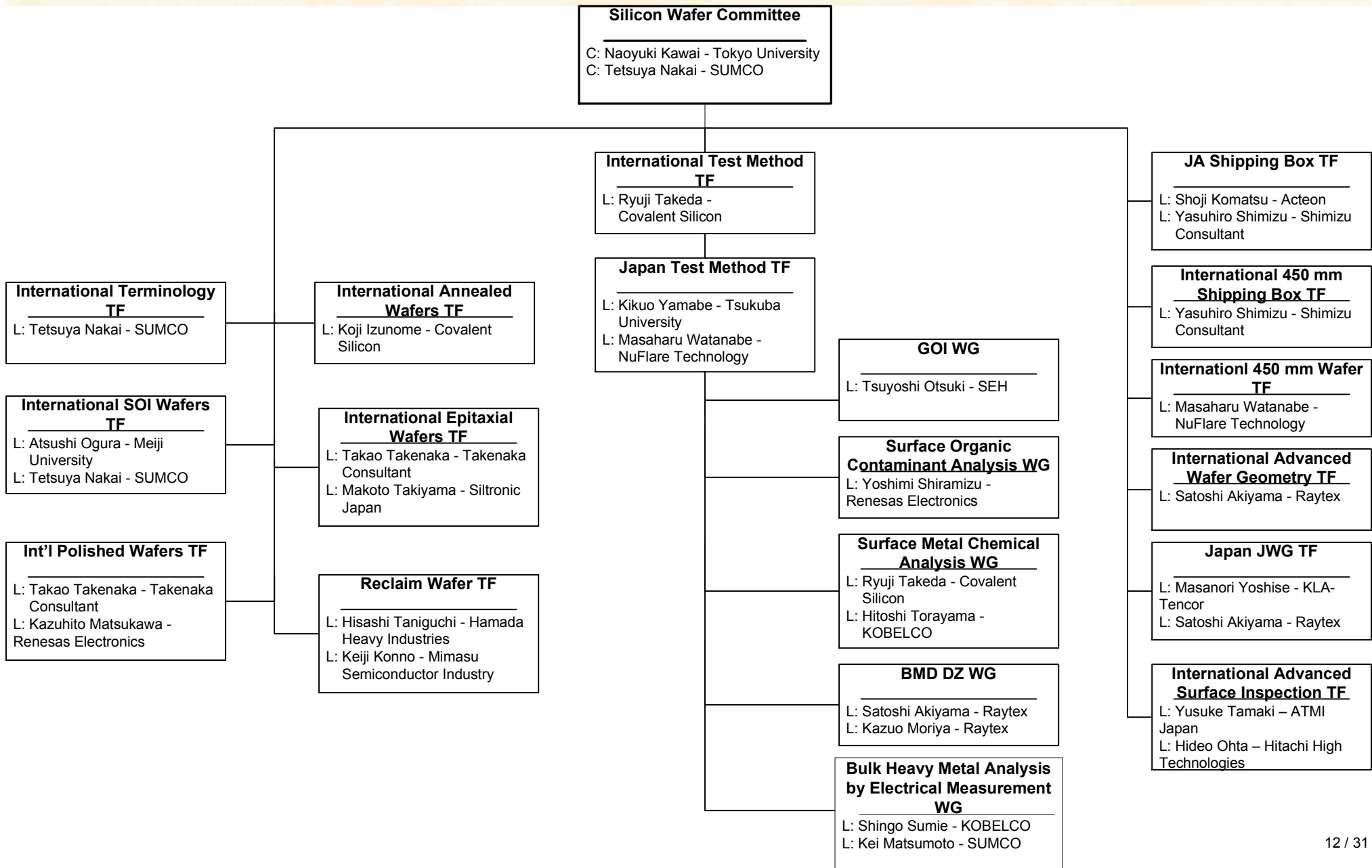

SEMI Japan Compound and Micropatterning Committees

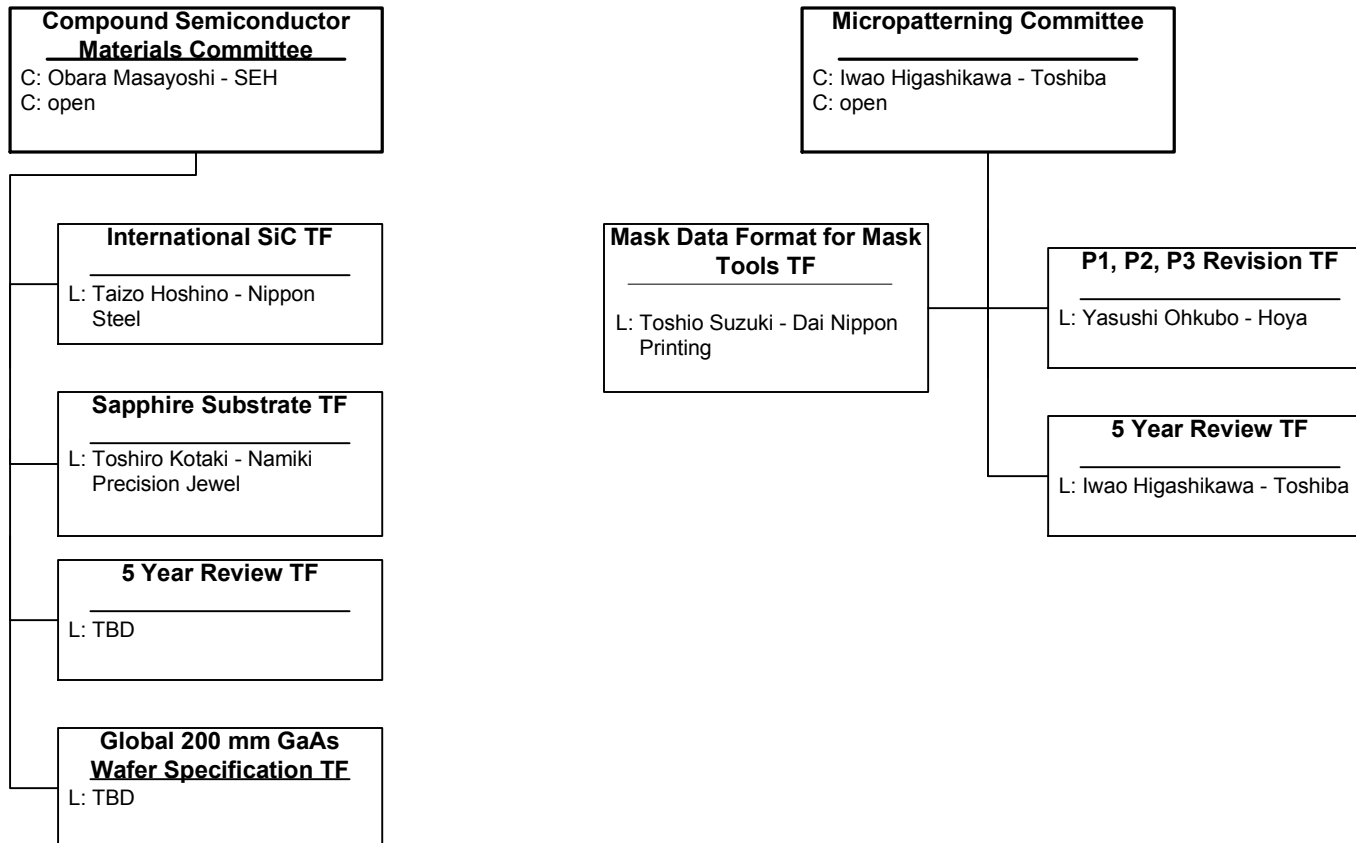

SEMI Japan Test and Packaging Committees

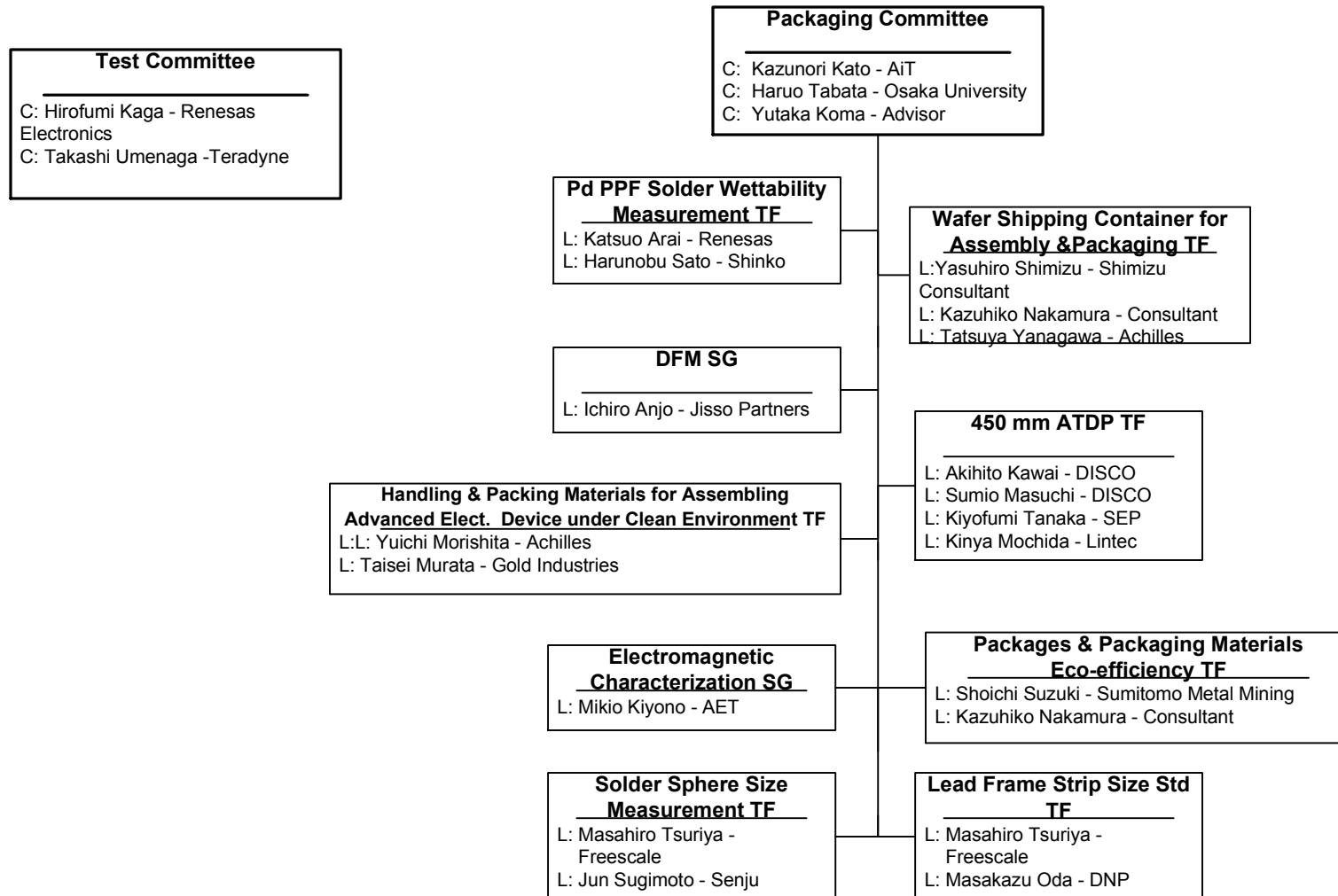

SEMI Korea Regional Standards Organization

Facilities Committee

C: Kwang Sun Kim - KUT
C: Insoo Cho - Shinsung ENG

Information & Control Committee

C: SeokGi Jeong - KC-Tech
C: Chul Hong Ahn - Hynix
C: Gun Woo Lee - Miracom Inc.

EHS WG

L: Seung Jong Ko - Hynix
L: Hyunsuk Kim - Samsung
Electronics

FPD Committee

C: JongSeo Lee - Samsung
Electronics
C: Il-Ho (William) Kim - Light
Measurement Solution

FPD Metrology Committee

C: JongSeo Lee - Samsung
Electronics
C: Il-Ho (William) Kim - Light
Measurement Solution

SEMI Korea FPD and FPD Metrology Committees

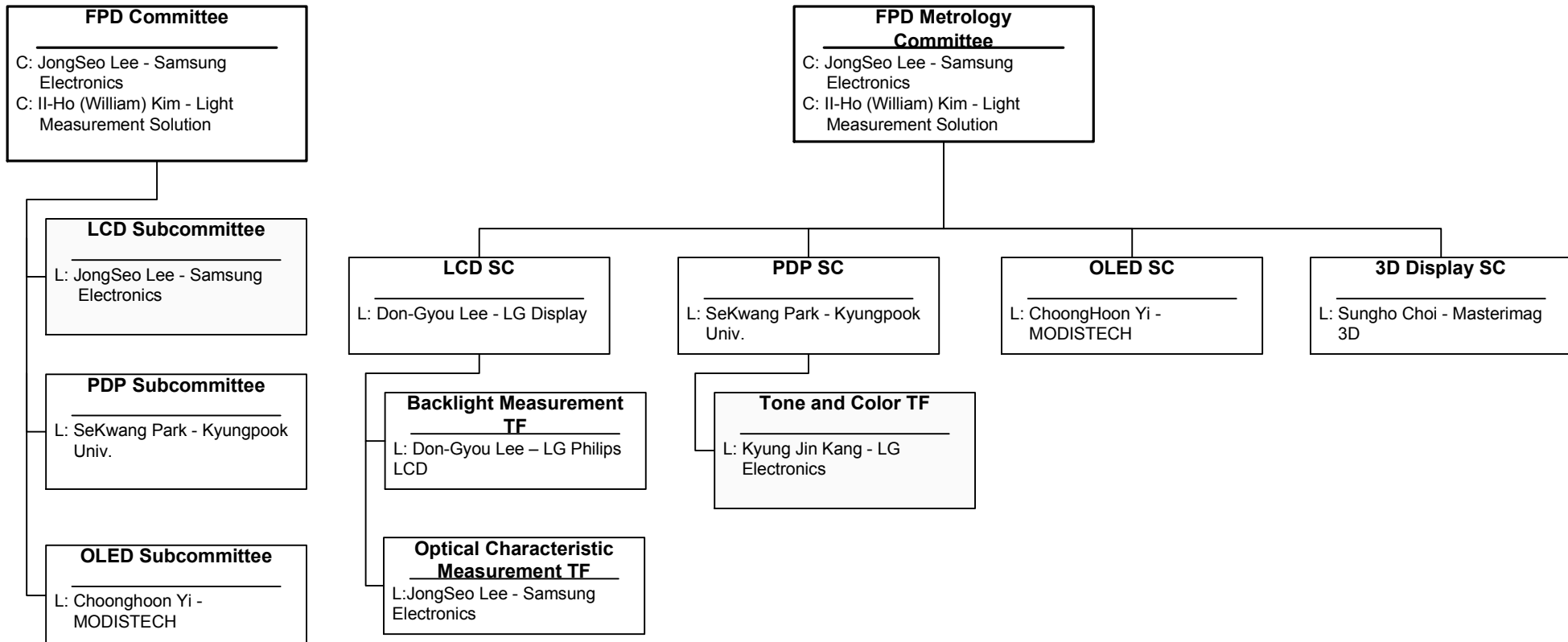

SEMI Korea Information & Control, Facilities Committees, and EHS WG

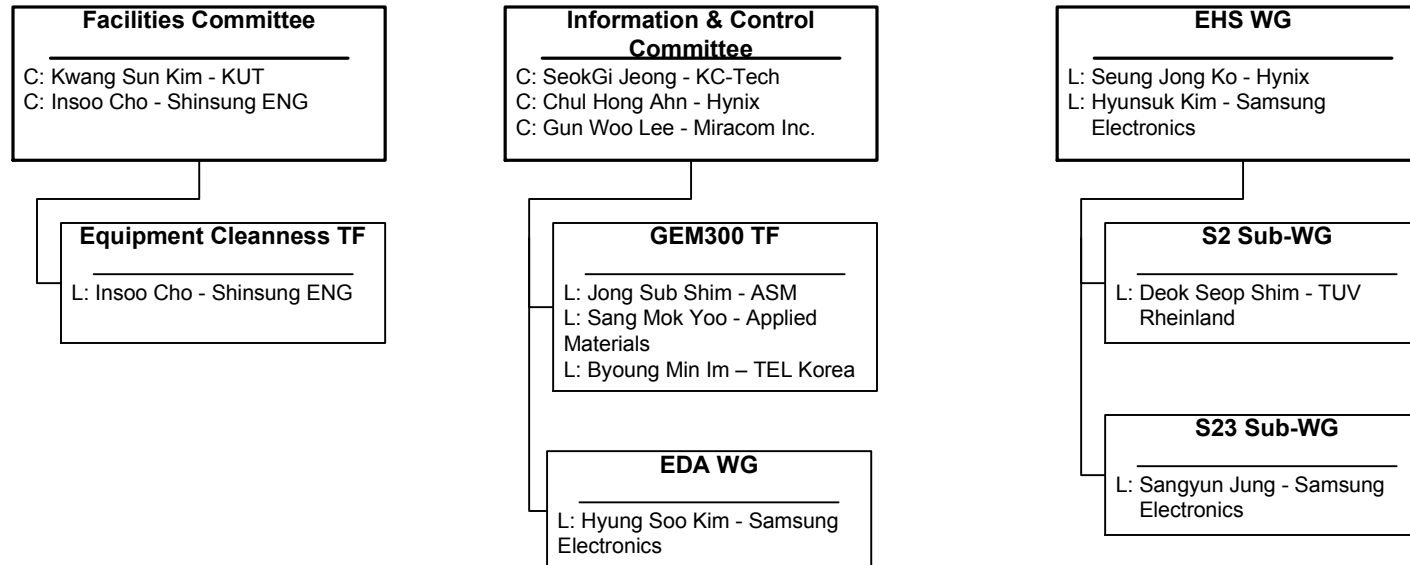

SEMI N.A. Regional Standards Organization

Co-Chairs: Jackie Ferrell - ISMI & Sean Larsen – Lam Research AG

Vice-Chair: Mark Crockett – MEMSMART

3DS-IC

Committee

C: Richard Allen - SEMATECH
C: Urmi Ray - Qualcomm
C: Chris Moore – Semilab
C: Sesh Ramaswami – Applied Materials

Flat Panel Display Committee

C: Bill Colbran - Engenuity Systems

MEMS/NEMS Committee

C: Win Baylies - BayTech Group
C: Mark Crockett - MEMSMART

Physical Interfaces & Carriers Committee

C: Matt Fuller - Entegris
C: Mutaz Haddadin - Intel

Automated Test Equipment Committee

C: Ajay Khoche – Khoche Consulting

Gases Committee

C: Tim Volin - Parker Hannifin

Metrics Committee

C: David Bouldin - Fab Consulting
C: Mark Frankfurth - Cymer

Silicon Wafer Committee

C: Dinesh Gupta - STA
C: Noel Poduje - SMS
VC: Mike Goldstein - Intel

Compound Semiconductor Materials Committee

C: Russ Kremer - Freiburger Compound Materials
C: James Oliver - Northrop Grumman

HB-LED Committee

C: Iain Black - Philips
C: Chris Moore - Semilab
C: Bill Quinn – Veeco
C: David Reid - Silian

Microlithography Committee

C: Wes Erck - Wes Erck & Associates
C: Rick Silver - NIST

Traceability Committee

C: Win Baylies - BayTech Group
C: Yaw Obeng - NIST

Environmental Health & Safety Committee

C: Chris Evanston - Salus Engineering
C: Sean Larsen – Lam Research AG
C: Eric Sklar - Safety Guru
C: James Beasley - ISMI

Information & Control Committee

C: Jack Ghiselli – Ghiselli Consulting
C: David Bricker - AMAT
C: Lance Rist - RistTex

Photovoltaic Committee

C: Win Baylies - Baytech Group
C: James Moyné – Applied Materials

NA RSC Technical Architect Board

C: James Moyné - Applied Materials
C: Yaw Obeng - NIST

Facilities Committee

C: Phil Naughton - Applied Materials
C: Steve Lewis - CH2M Hill

Liquid Chemicals Committee

C: Frank Flowers - FMC
C: Frank Parker - ICL

Photovoltaic Materials Committee

C: Lori Nye – Brewer Science
C: Dick Hockett – Evans Analytical Group

SEMI N.A. Gases Committee

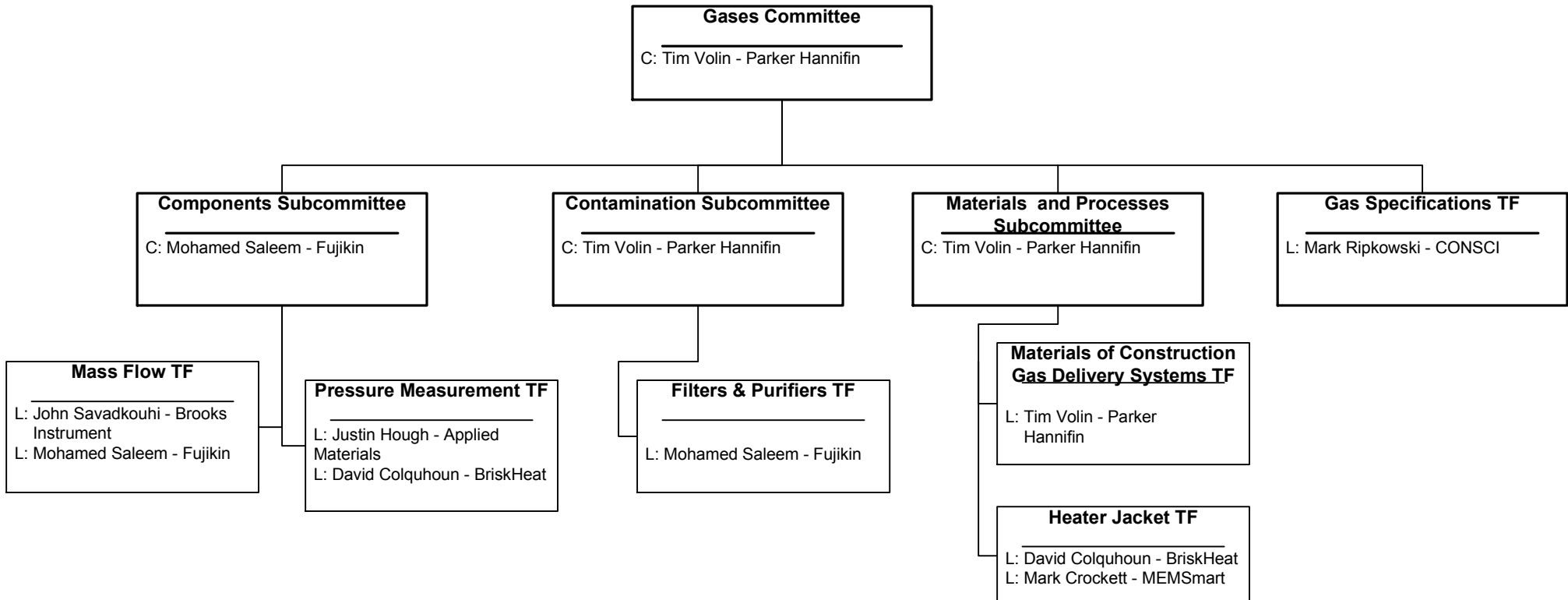

SEMI N.A. Facilities & Liquid Chemicals Committees

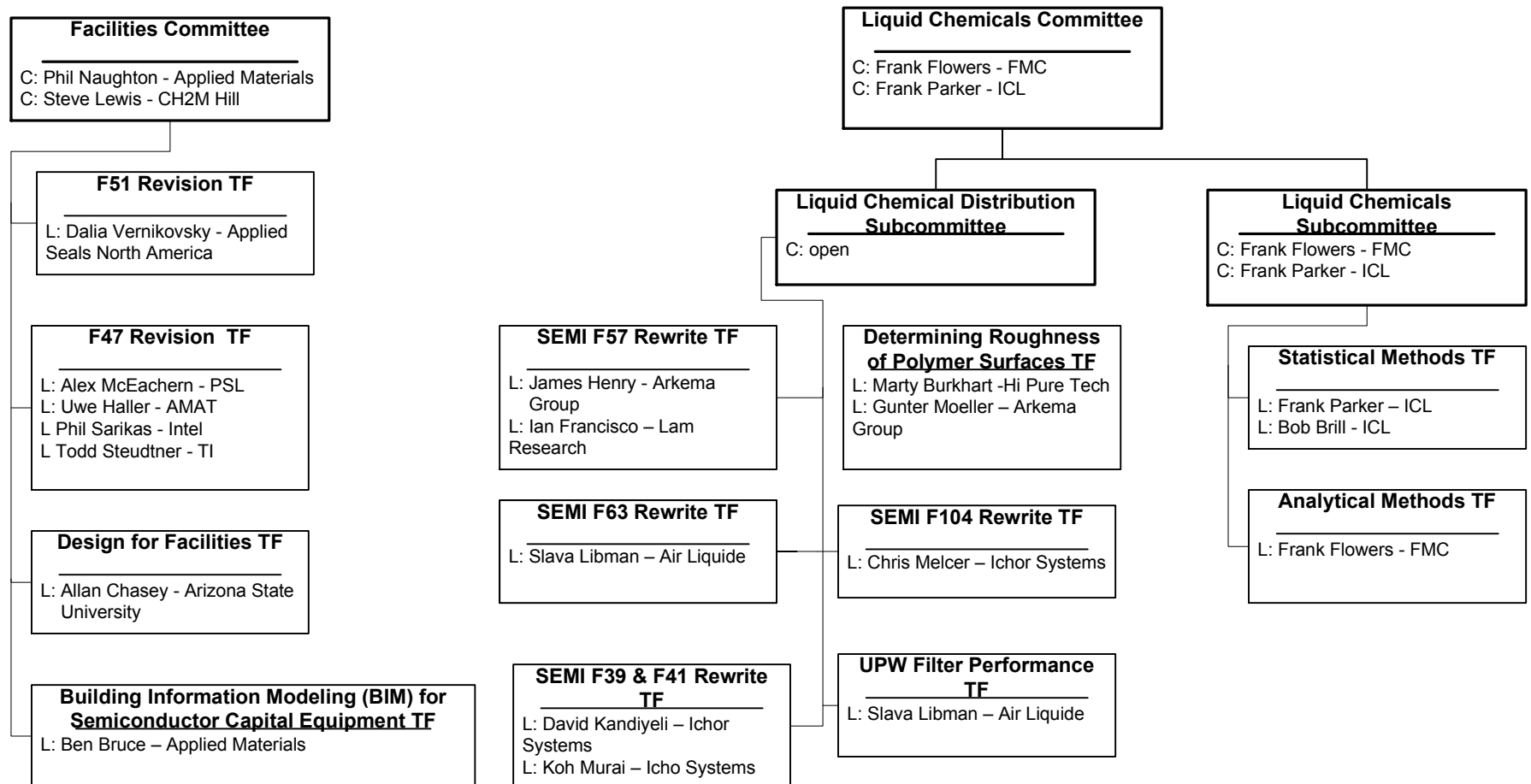

SEMI N.A. Information & Control and Automated Test Equipment Committees

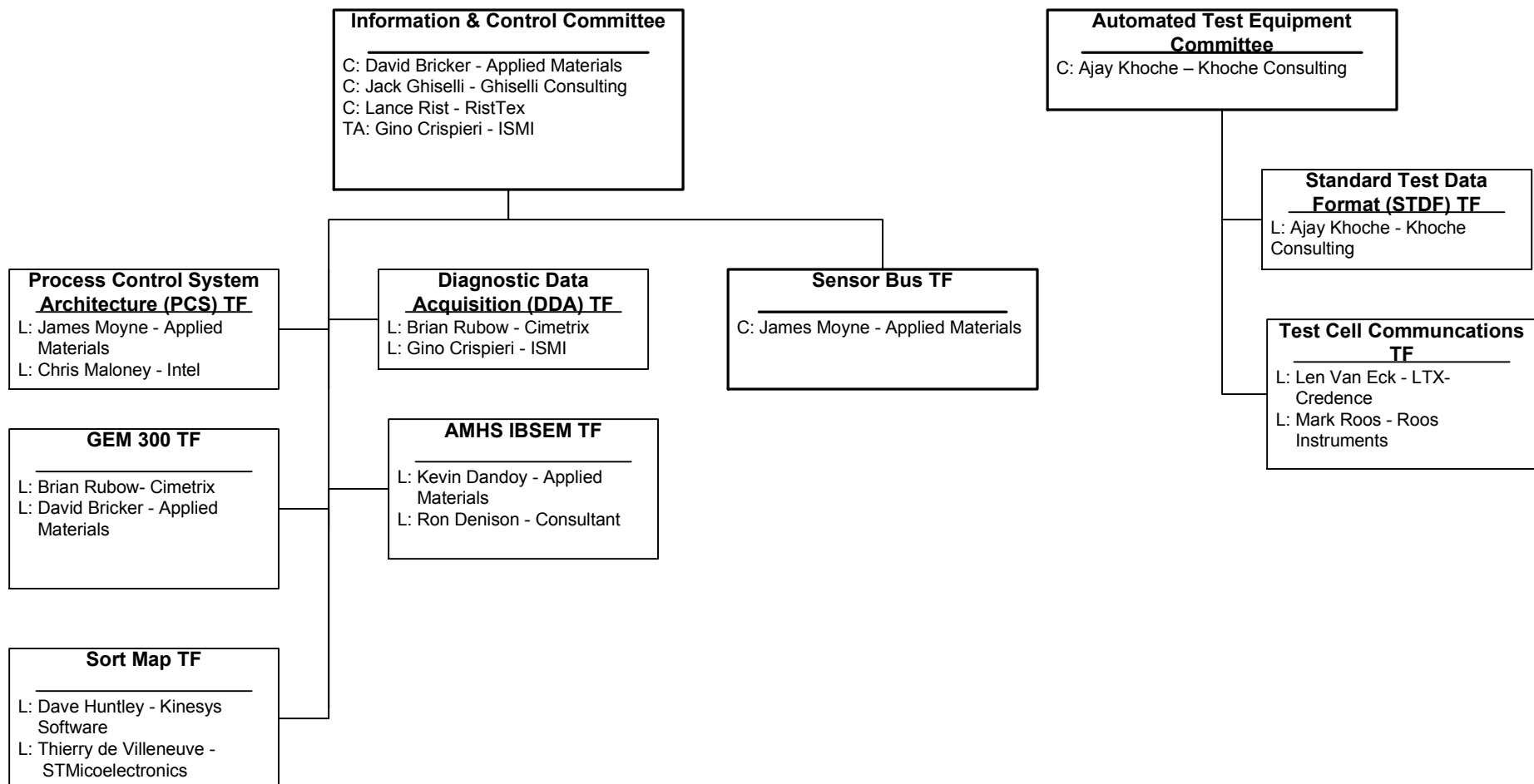

SEMI N.A. Physical Interfaces & Carriers and Metrics Committees

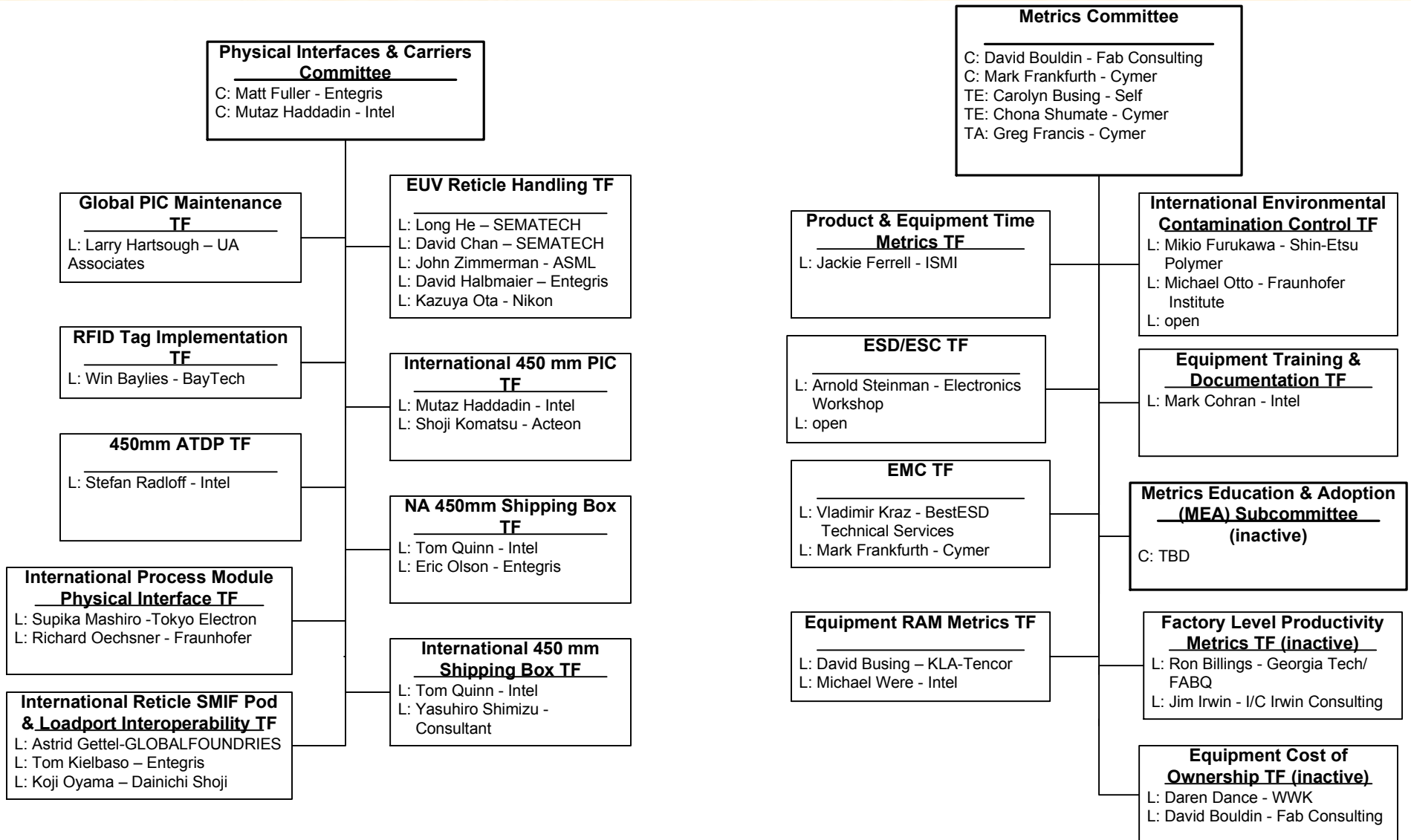

SEMI N.A. FPD, Microlithography & Traceability Committees

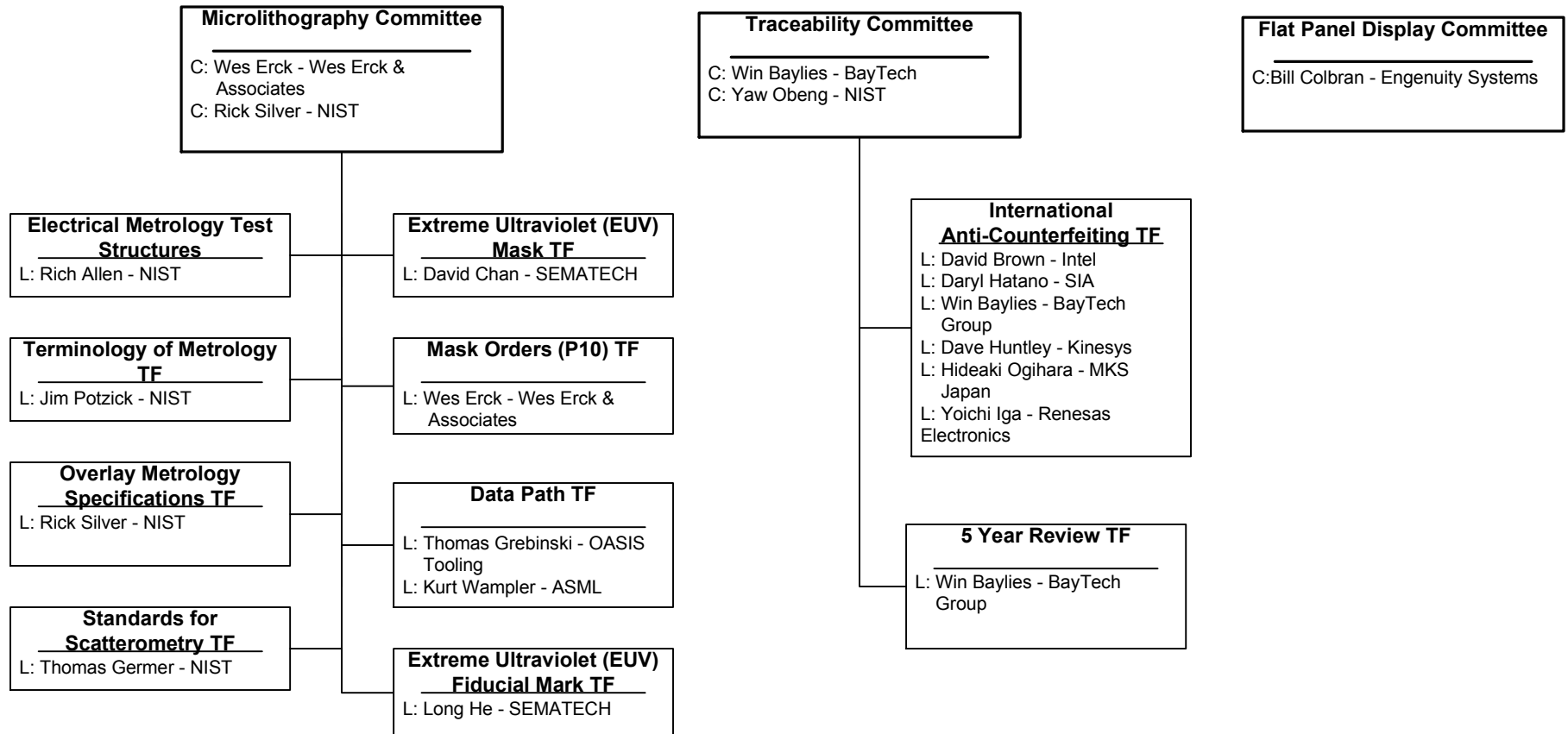

SEMI N.A. Compound Semiconductor & Silicon Wafer Committees

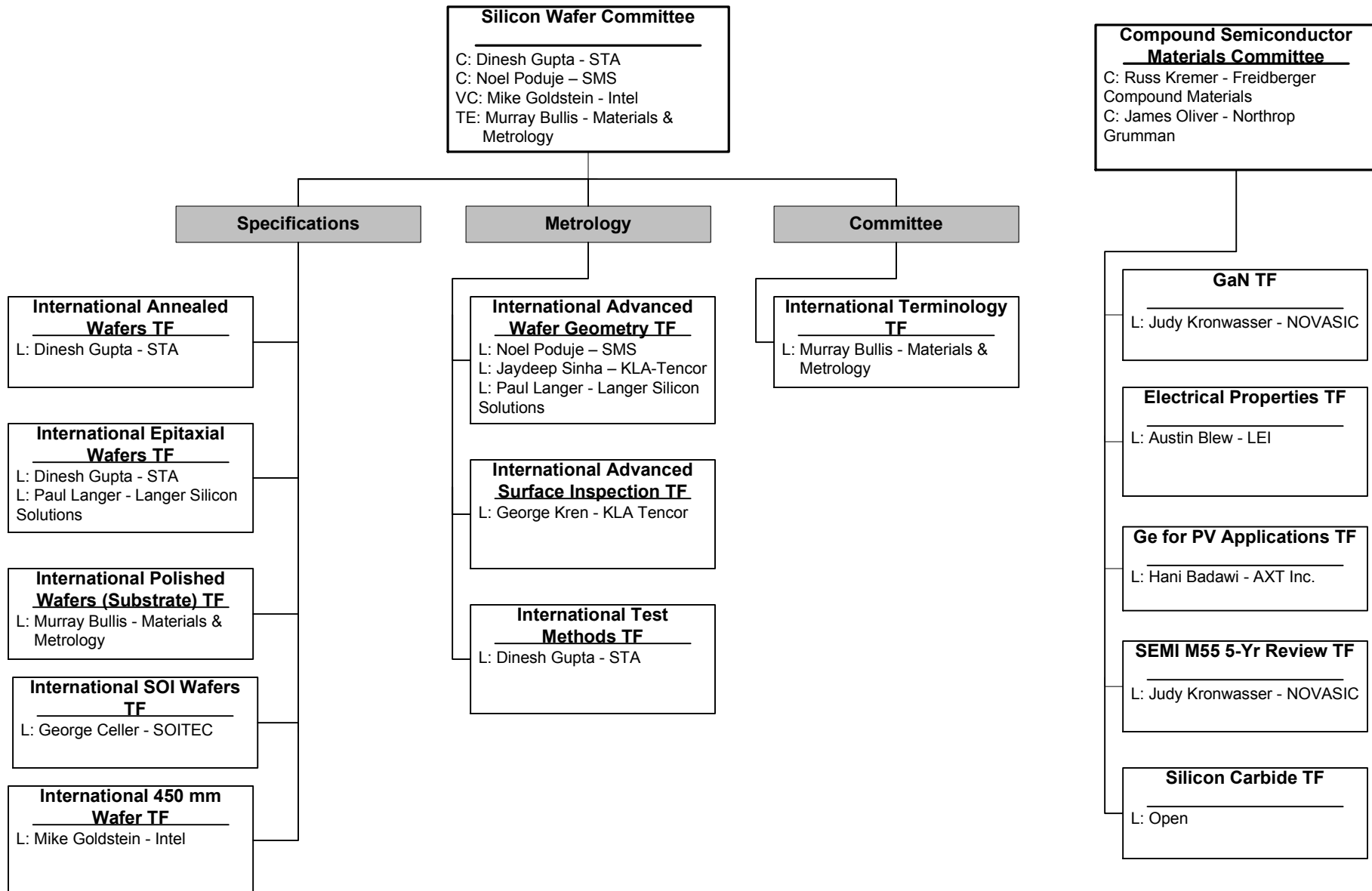

SEMI N.A. Photovoltaic & Photovoltaic Materials Committees

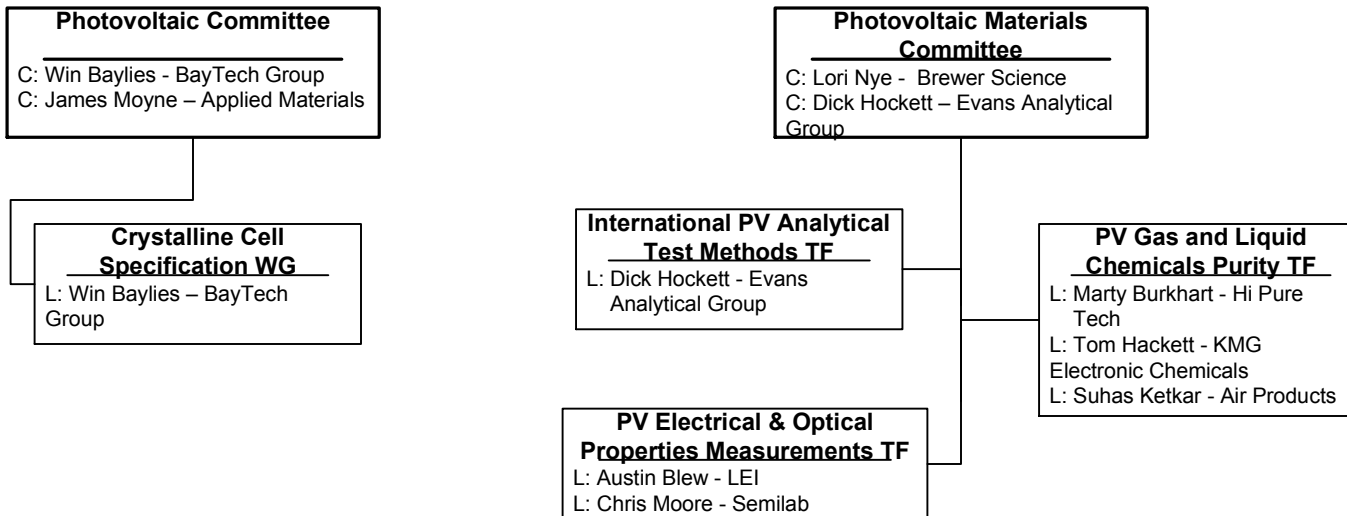

SEMI N.A. Environmental, Health & Safety Committee

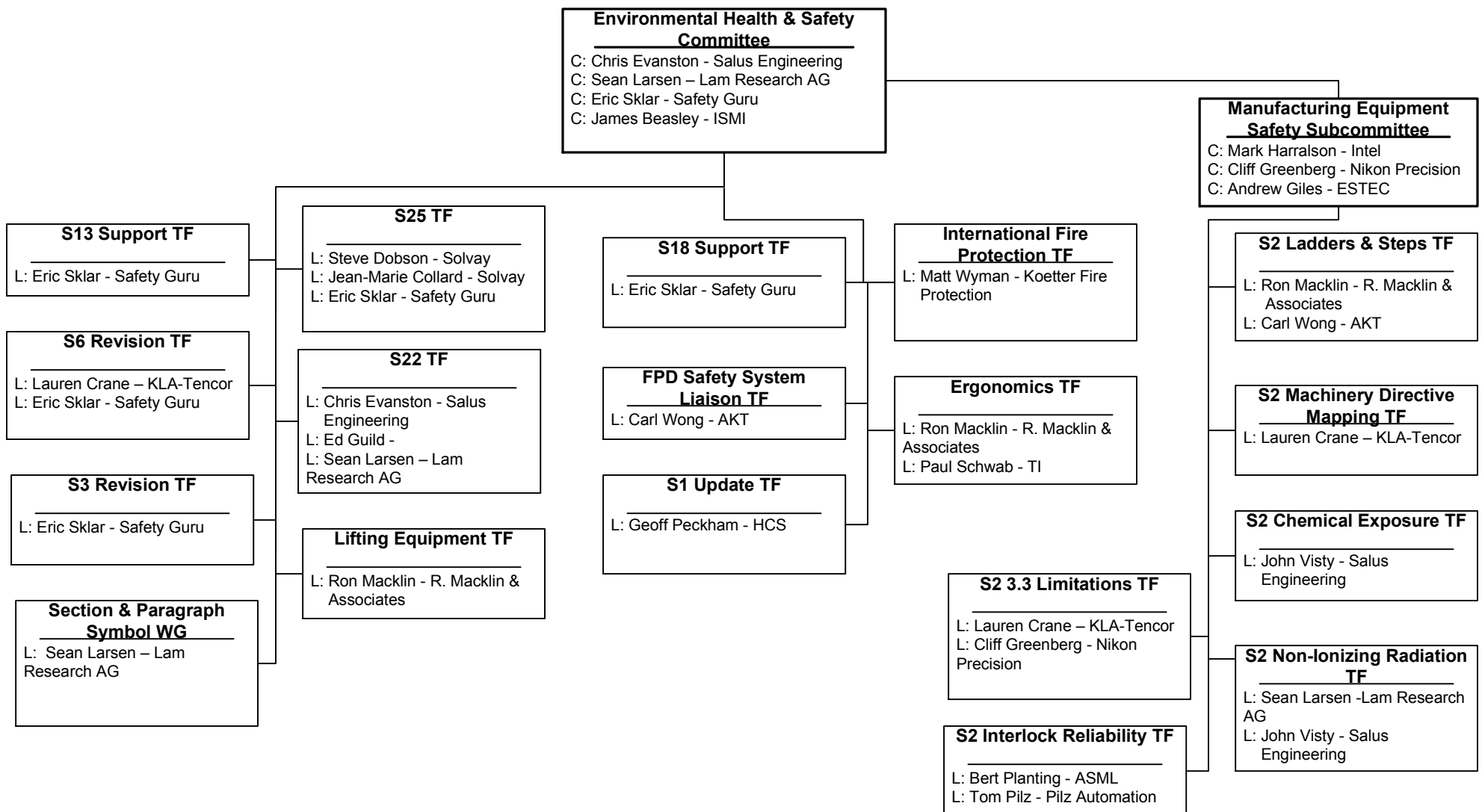

SEMI N.A. 3DS-IC, HB-LED & MEMS/NEMS

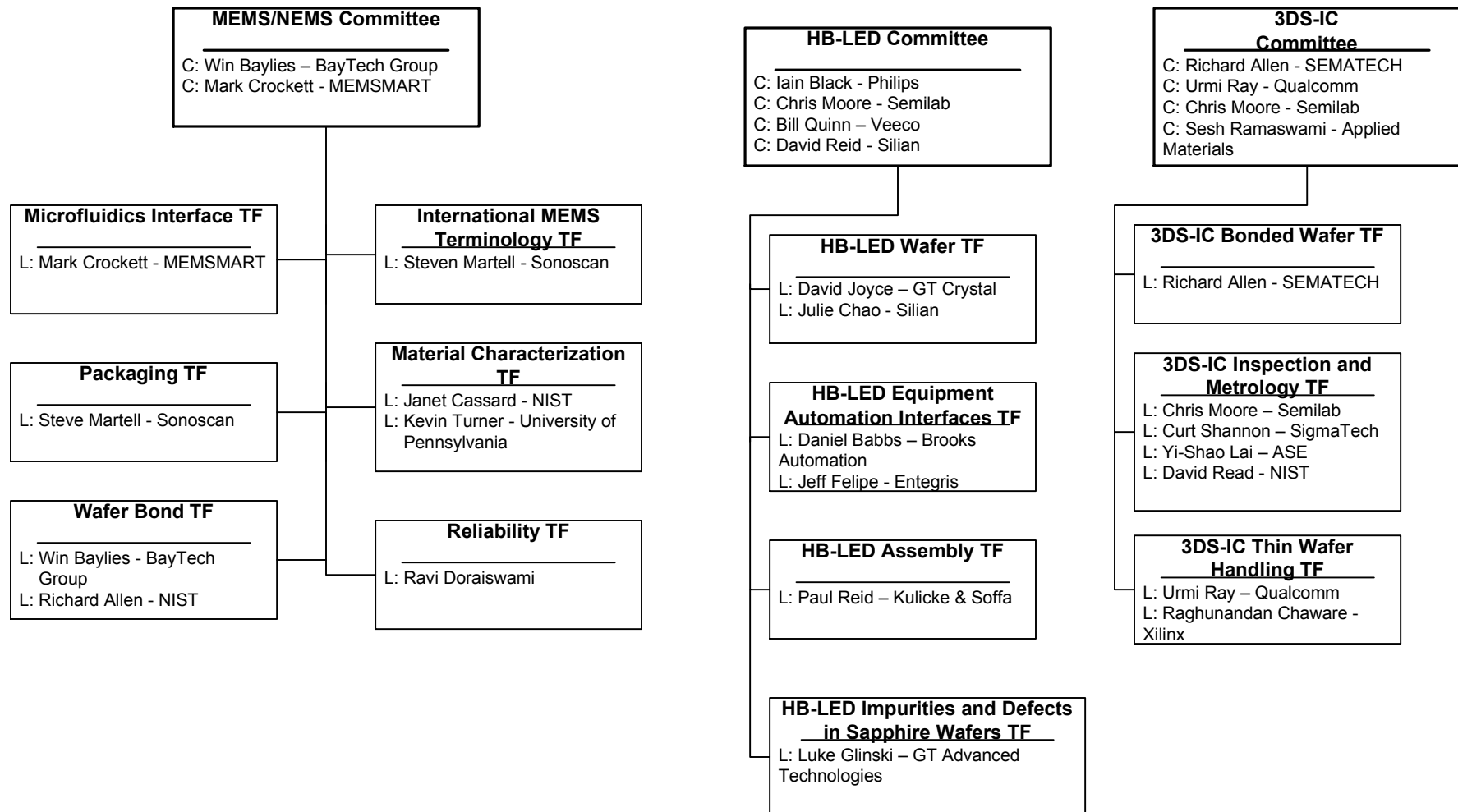

SEMI Taiwan Regional Standards Organization

ISC Taiwan Advisor

Tzeng-Yow Lin - CMS/ITRI

**Information & Control
Committee**

C: Robert Chien - TSMC

**Environmental Health & Safety
Committee**

C: S. W. Yu - SAHTECH
C: F. M. Hsu - TSMC

Flat Panel Display Committee

C: Tzeng-Yow Lin - CMS/ITRI
C: Jia-Ming Liu - TMDA

Photovoltaic Committee

C : B. N. Chuang - CMS/ITRI
C : J.S. Chen-TeraSolar
C : Ray Sung-UL Taiwan

**3DS-IC
Committee**

C: Tzu-Kun Ku - ITRI
C: Wendy Chen – King Yuan
Electronics
C: Yi-Shao Lai - ASE

SEMI Taiwan Information & Control and Photovoltaic Committees

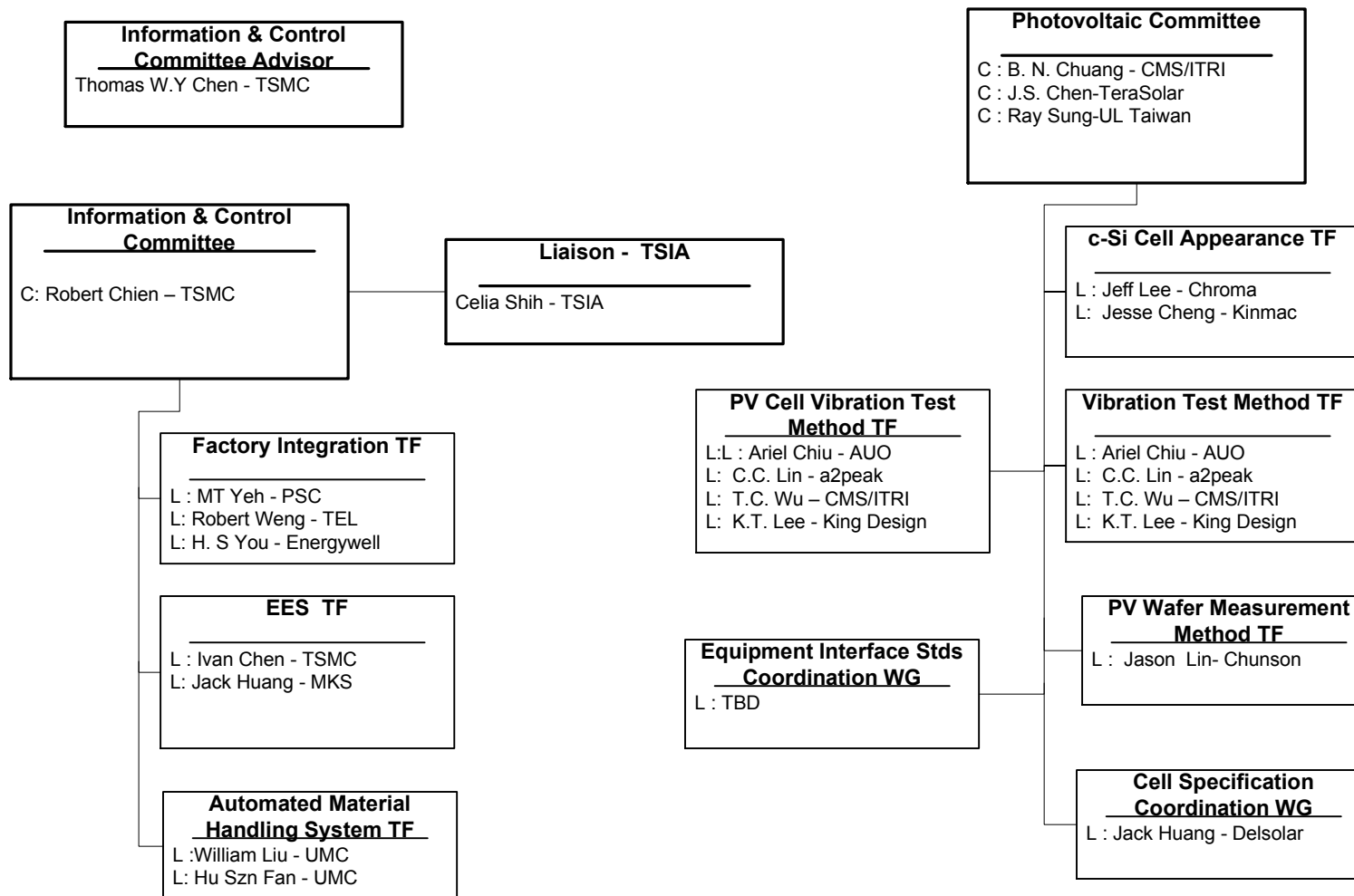

SEMI Taiwan 3DS-IC & Environmental, Health & Safety Committees

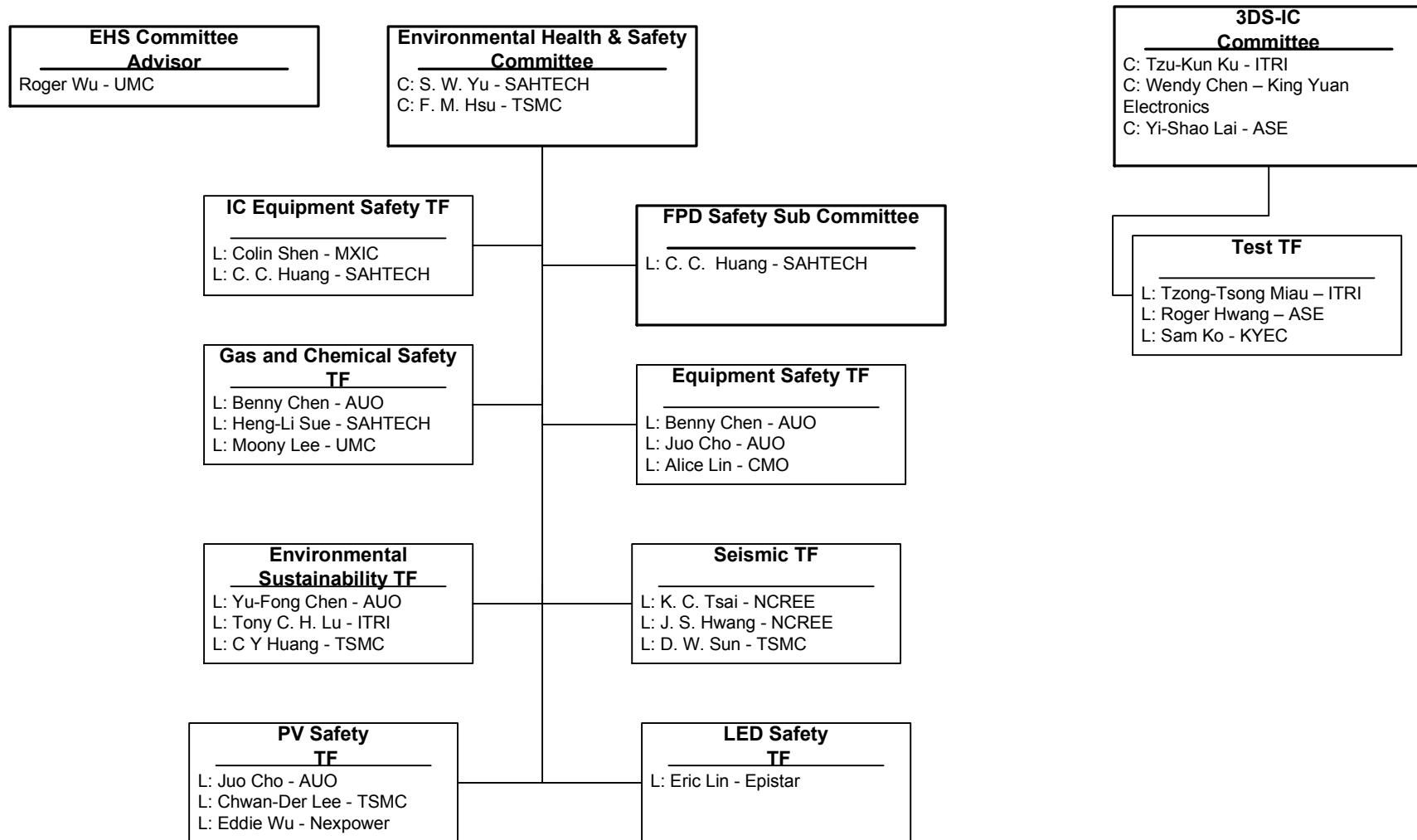

SEMI Taiwan Flat Panel Display Committee

