



## SEMI® INTERNATIONAL STANDARDS

# Organizational Chart

- China
- Europe
- Japan
- Korea
- North America
- Taiwan

*Last updated: February 09, 2012*

# SEMI Europe Regional Standards Organization

Co-chairs: Jean-Marie Collard - Solvay Chemicals, Werner Bergholz - Jacobs University of Bremen

## **Compound Semiconductor Materials Committee**

C: A. Weber - SiCrystal

## **EHS Committee**

C: B. Planting - ASML  
C: T. Pilz – Pilz Automation

## **Photovoltaic Materials Committee**

C: L. Fabry - Wacker Chemie  
C: H. Aulich - PV Crystalox Solar

## **Equipment Automation Committee**

C: A. Honold - InReCon (I&C, PIC, Metrics)  
C: M. Carrubba - Numonyx (I&C, PIC)  
C: L. Pfitzner - FhG IISB (Metrics)  
VC: F. Petzold - Trustsec (I&C)

## **Gas & Liquid Chemicals Committee**

C: J-M Collard - Solvay Chemicals  
C: G. Ferrier - Air Products  
VC: G. De Vos - FFEM

## **Photovoltaic Automation Committee**

C: T. Körner - Q-Cells  
C: M. Zenning - Jonas & Redmann  
C: E. Teichmann - Peer Group

## **Silicon Wafer Committee**

C: W. Bergholz - Jacobs University of Bremen  
C: P. Wagner - Consultant

# SEMI Europe EHS, Equipment Automation, and Gas & Liquid Chemicals Committees

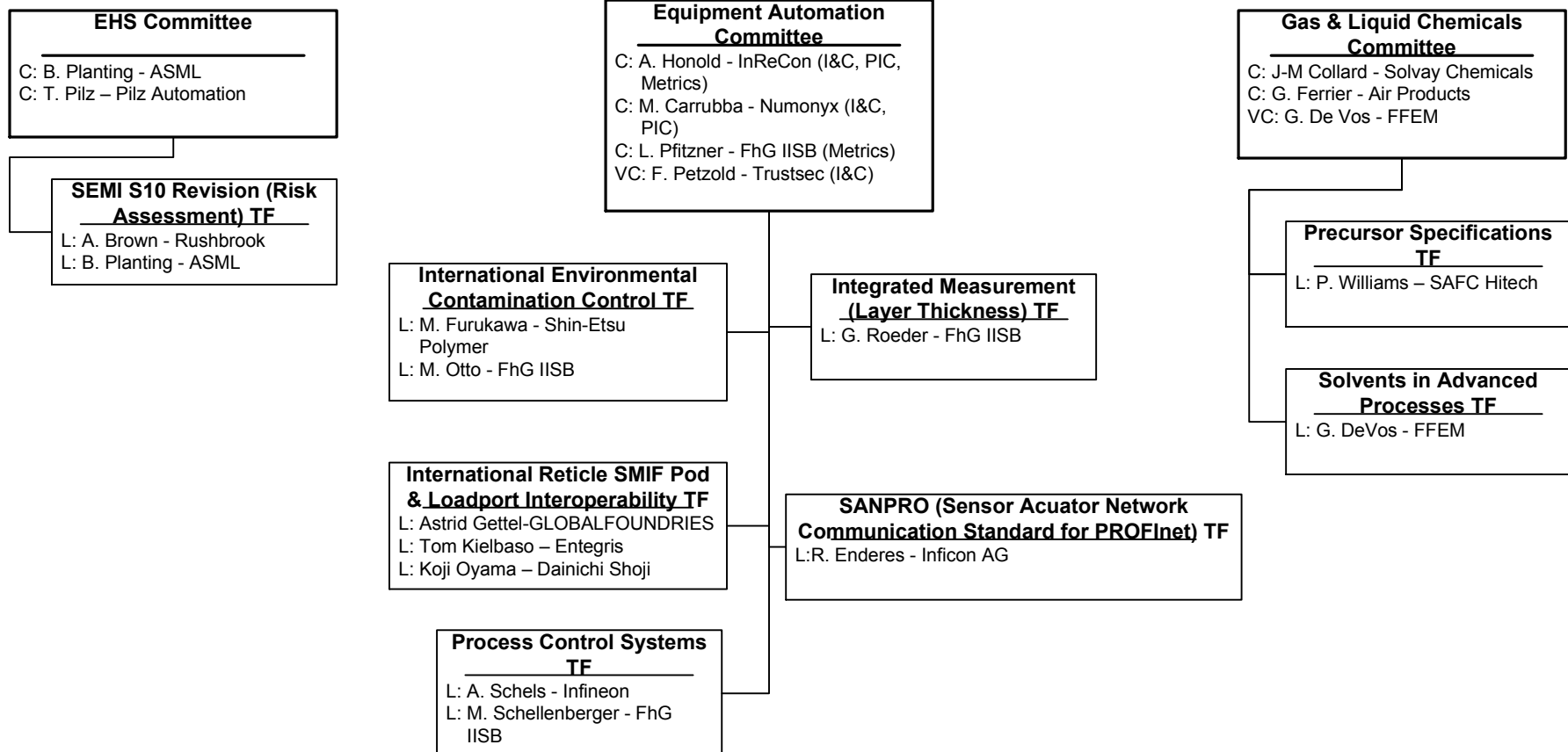

# SEMI Europe PV, PV Automation, Compound Semiconductor and Silicon Wafer Committees

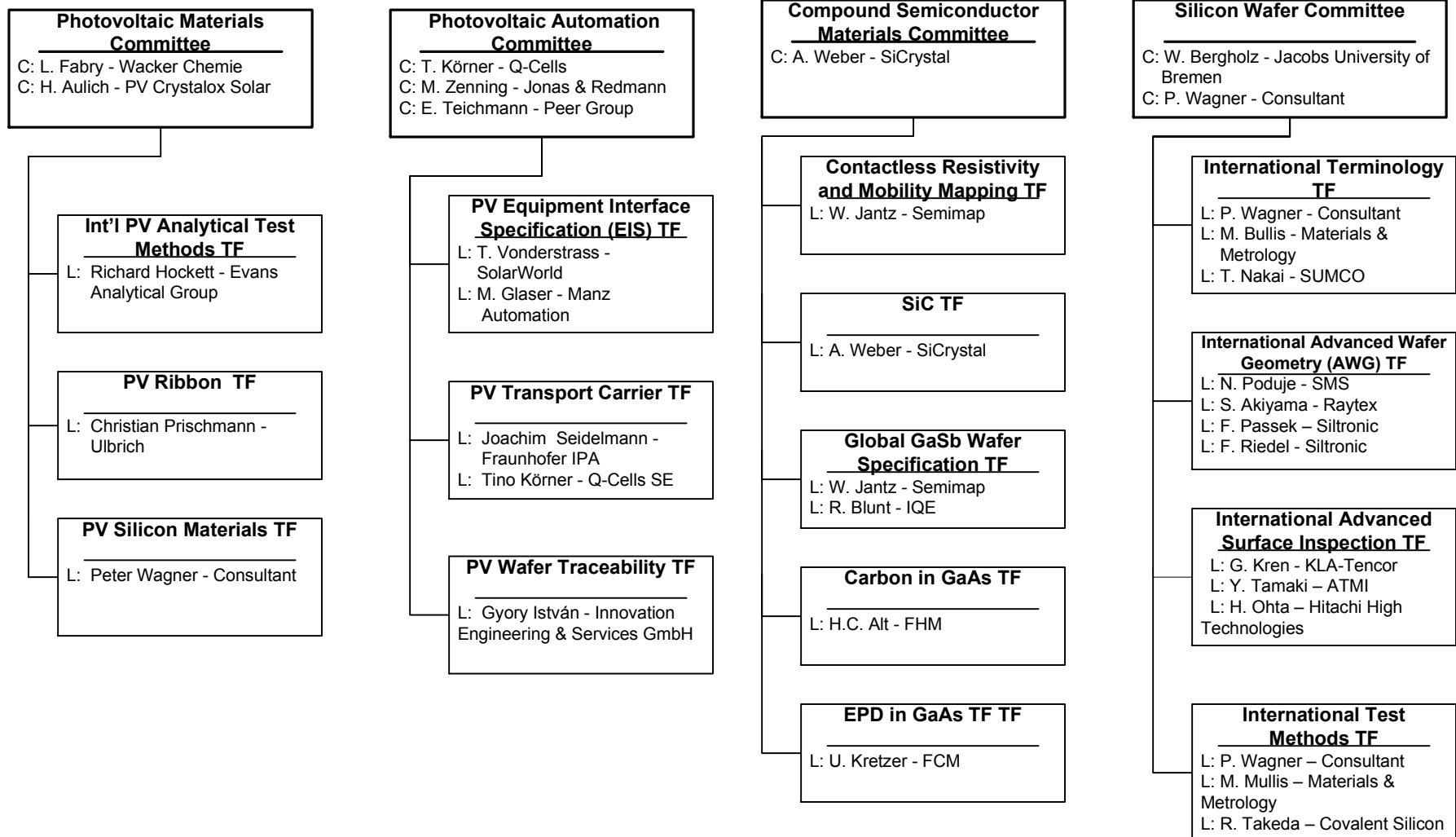

# SEMI Japan Regional Standards Organization

Co-Chair: Shigeru Kobayashi - Renesas Technology      Co-Chair: Makoto Yamamoto - Muratec Automation  
Vice Chair: Supika Mashiro - TEL

## Information & Control Committee

C: Takayuki Nishimura - DNS  
C: Mitsuhiro Matsuda - Hitachi Kokusai Electric

## Physical Interfaces & Carriers Committee

C: Shoji Komatsu - Acteon  
C: Tsuyoshi Nagashima - Miraial  
C: Tsutomu Okabe - TDK

## Metrics Committee

C: Toshio Murakami - Murakami Corporation  
C: Mikio Furukawa - Shin-Etsu Polymer

## Micropatterning Committee

C: Iwao Higashikawa - Toshiba

## Traceability Committee

C: Michio Honma - Renesas Electronics  
C: Hirokazu Tsunobuchi - Keyence

## Photovoltaic Materials Committee

C: Takashi Ishihara - Mitsubishi Electric  
C: Kazuhiko Kashima - Covalent Materials  
C: Masaaki Yamamichi - AIST

## Photovoltaic Committee

C: Hiromu Takatsuka - Mitsubishi Heavy Industries  
C: Kazuhiko Kashima - Covalent Materials  
C: Masaaki Yamamichi - AIST  
C: Terry Asakawa - TEL

## Photovoltaic Automation Committee

C: Terry Asakawa - TEL  
C: Emi Ishikawa - Atelier Ishikawa  
C: Makoto Ishikawa - Nisshinbo Mechatronics

## Liquid Chemicals Committee

C: Hiroshi Tomita - Toshiba  
C: Kenji Sugimoto - DNS

## Packaging Committee

C: Kazunori Kato - AiT  
C: Masahiro Tsuruya - Freescale  
C: Yutaka Koma - Advisor

## Test Committee

C: Hirofumi Kaga - Renesas Electronics  
C: Takashi Umenaga - Teradyne

## Environmental Health & Safety Committee

C: Hidetoshi Sakura - Intel  
C: Supika Mashiro - TEL  
C: Moray Crawford - Hatsuta Selsakusho

## Gases & Facilities Committee

C: Hiromichi Enami - Hitachi High-Technologies  
C: Isao Suzuki - MKS Japan

## Compound Semiconductor Materials Committee

C: Masayoshi Obara - SEH  
C: TBD

## Silicon Wafer Committee

C: Naoyuki Kawai - University of Tokyo  
C: Tetsuya Nakai - SUMCO

## FPD Factory Automation Committee

C: Yasunobu Otagawa - Daihen  
C: Harumichi Hirose - Shibaura Mechatronics

## FPD Materials & Components Committee

C: Hisashi Aruga - Seiko Epson  
C: Tadaihiro Furukawa - Kyodo Printing  
C: Yoshihiko Shibahara - FUJIFILM

## FPD Mask Committee

C: Atsushi Okazaki - SK-Electronics  
C: Kaname Nitobe - HOYA

## FPD Metrology Committee

C: Ryoichi Watanabe - Toshiba Mobile Display  
C: Yuji Yoda - Otsuka Electronics

## Special Groups

Reporting to the JRSC

## Standardization Process Integration (SPI)

L: Supika Mahiro - TEL

## FPD Coordination Group

L: Yoshitada Nogami - SK Electronics  
L: Makoto Yamamoto - Muratec

# SEMI Japan PV, PV Materials, and PV Automation Committees

**Photovoltaic Materials  
Committee**  
C: Takashi Ishihara - Mitsubishi  
Electric  
C: Kazuhiko Kashima - Covalent  
Materials  
C: Masaaki Yamamichi - AIST

**Japan PV Materials TF**  
L: Masaaki Yamamichi - AIST  
L: Takashi Ishihara -  
Mitsubishi Electronic

**Photovoltaic Automation  
Committee**  
C: Emi Ishikawa - Atelier Ishikawa  
C: Terry Asakawa - TEL  
C: Makoto Ishikawa - Nisshinbo  
Mechatronics

**Global PV Equipment Interface  
Specification (PV-EIS) TF**  
L: Takashi Murakami - TEL  
L: Makoto Ishikawa - Nisshinbo  
Mechatronics

**PV Transport Carrier  
TF**  
L: Koji Ohyama - Dainichi Shoji  
L: Shuichi Inoue - Miraial

**Photovoltaic Committee**  
C: Hiromu Takatsuka - Mitsubishi  
Heavy Industries  
C: Kazuhiko Kashima - Covalent  
Materials  
C: Masaaki Yamamichi - AIST  
C: Terry Asakawa - TEL

**PV Safety SG**  
L: Yasuhiro Yamauchi -  
Mitsubishi Heavy Industries

# SEMI Japan PI&C and Metrics Committees

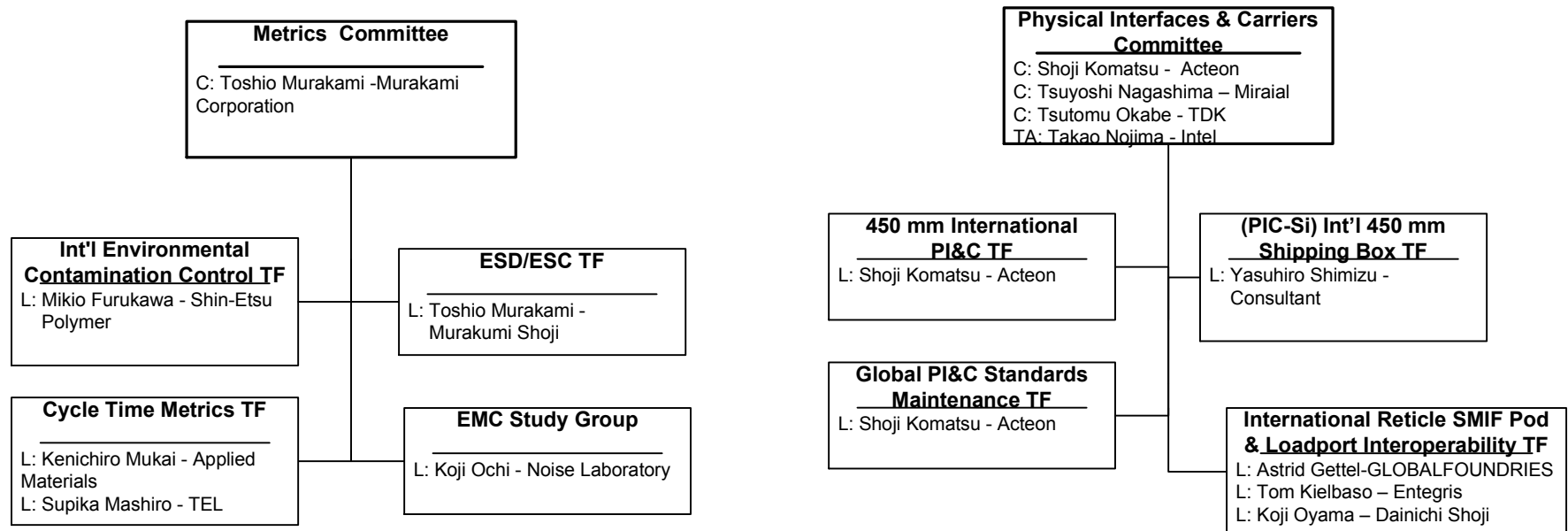

# SEMI Japan Information & Control, and Traceability Committees

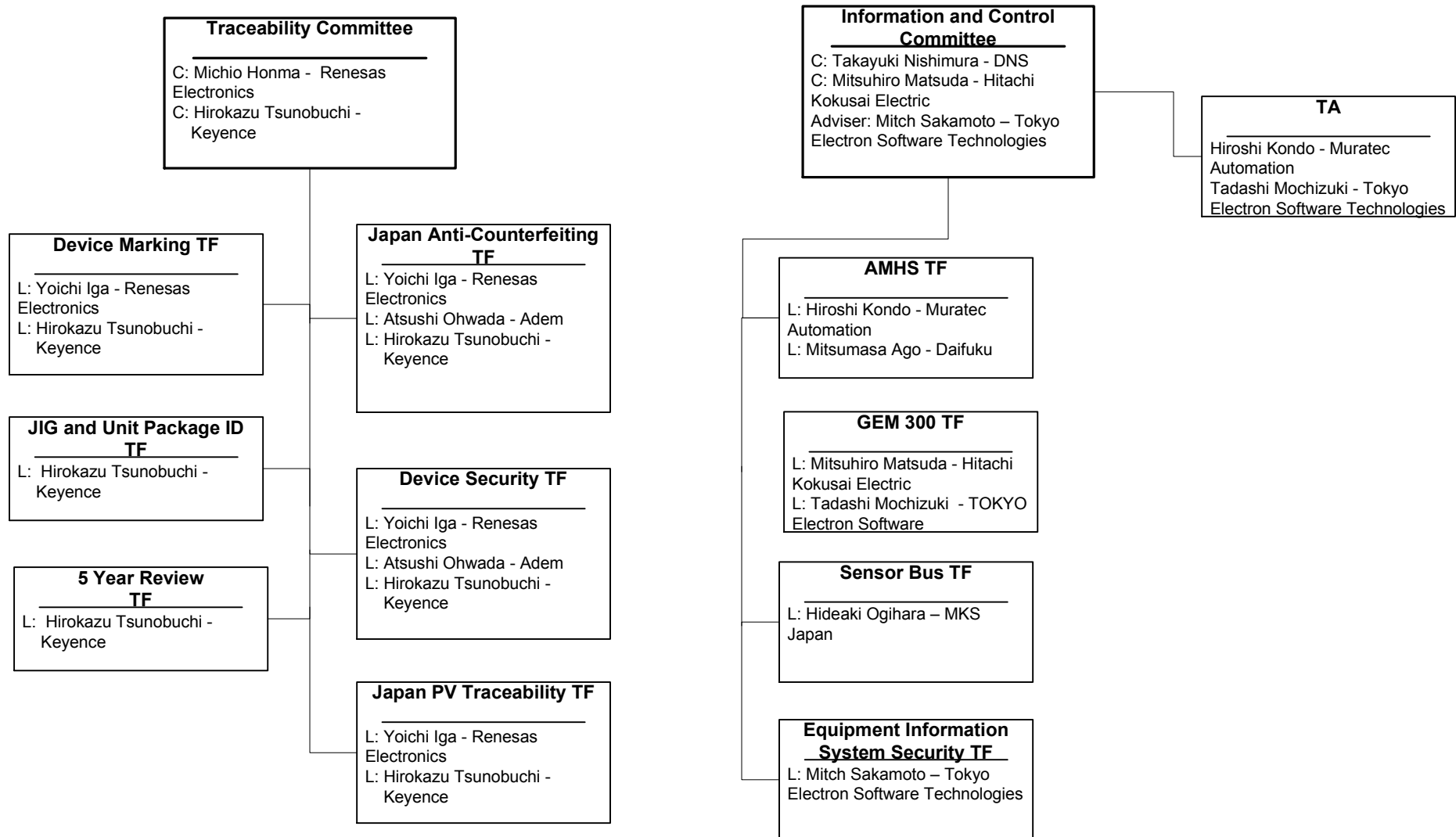

# SEMI Japan Gases & Facilities, and Liquid Chemicals Committees

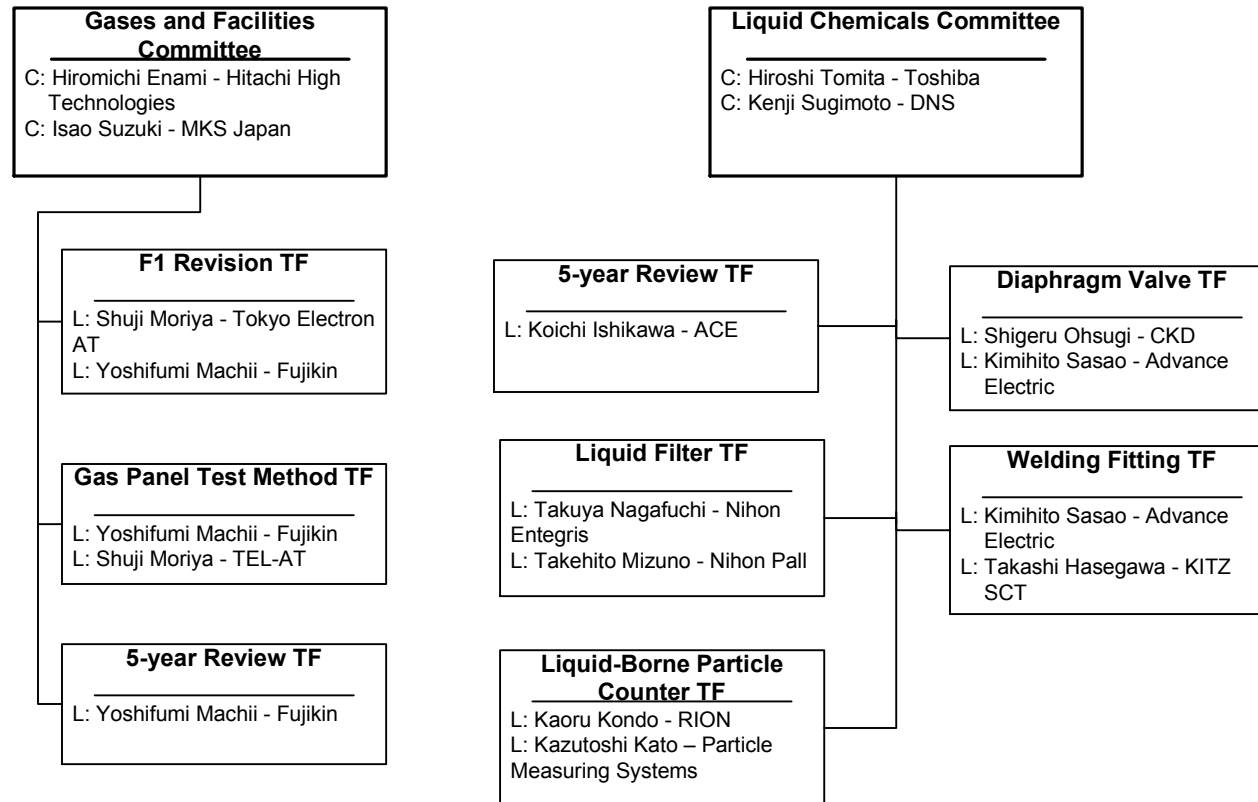

# SEMI Japan EHS Committee

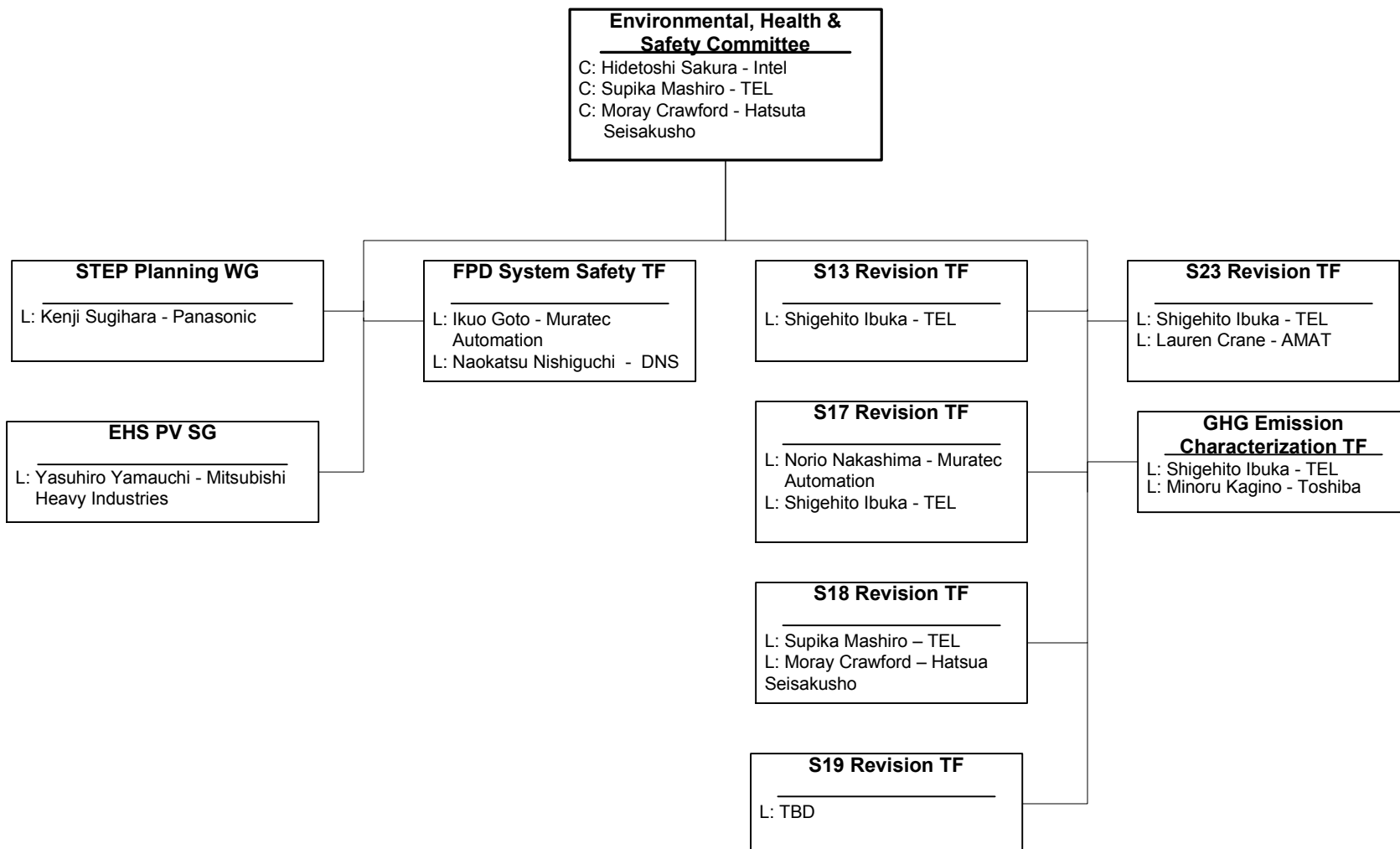

# SEMI Japan FPD Factory Automation, Materials & Components, Mask, and Metrology Committees

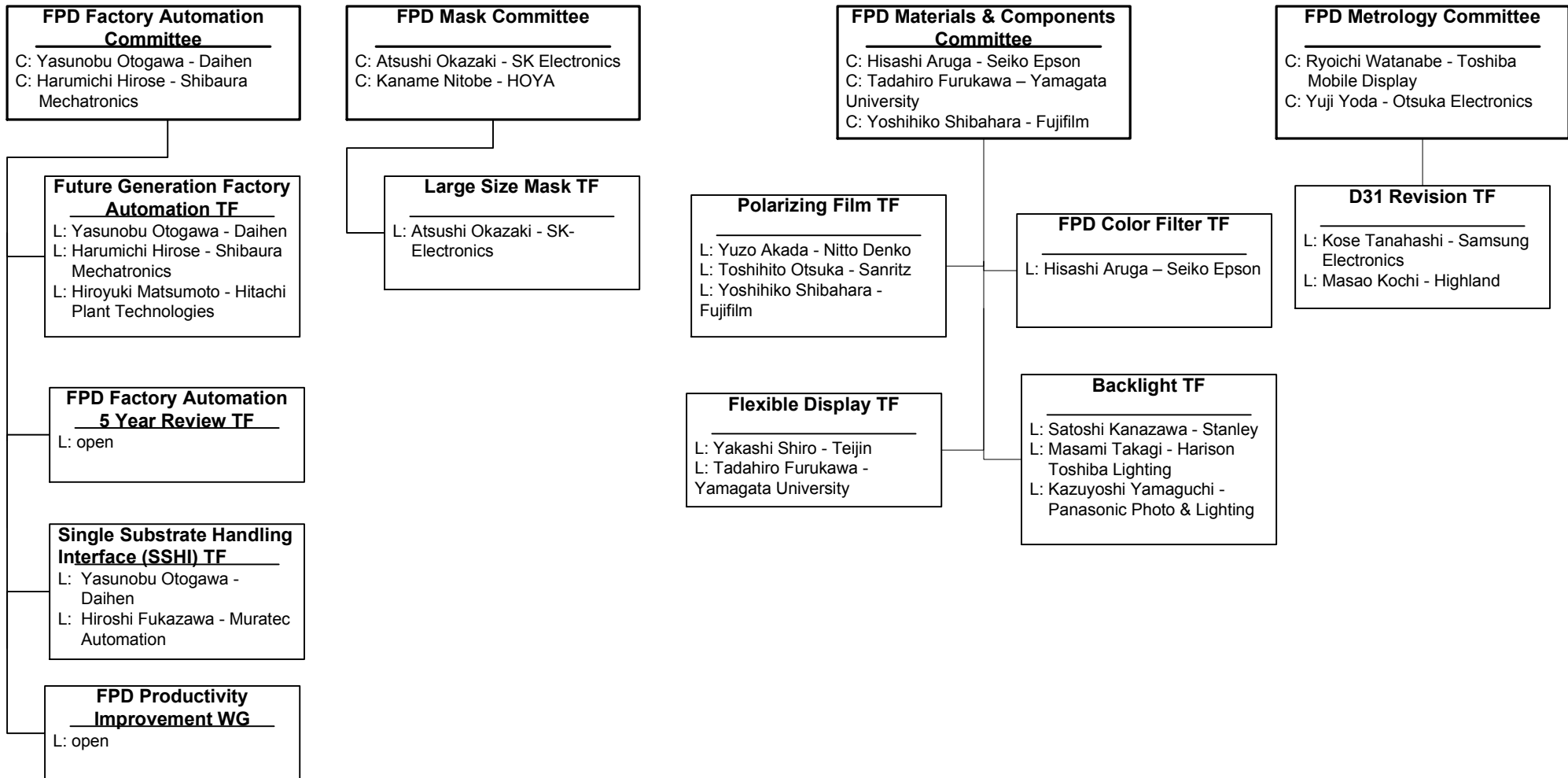

# SEMI Japan Silicon Wafer Committee

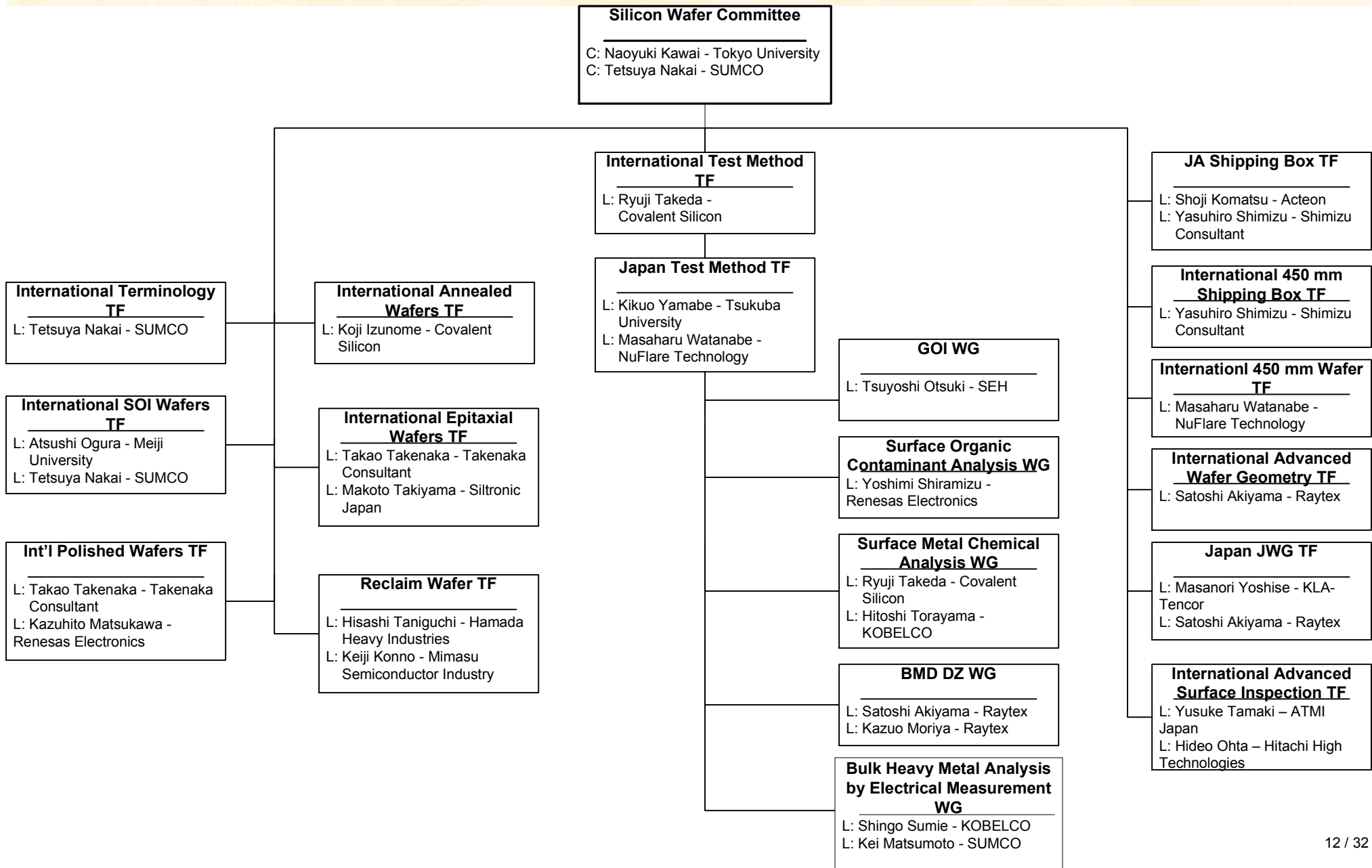

# SEMI Japan Compound and Micropatterning Committees

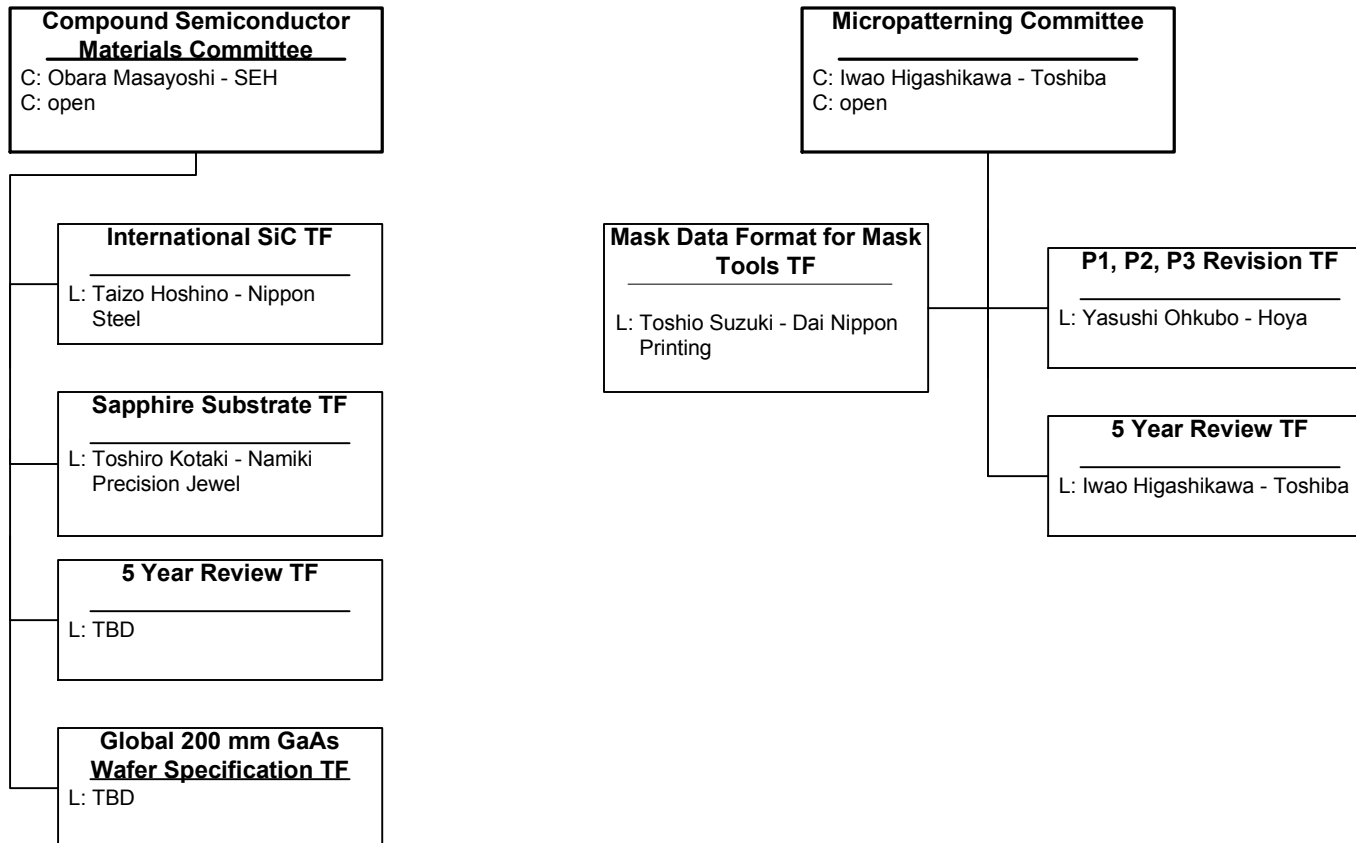

# SEMI Japan Test and Packaging Committees

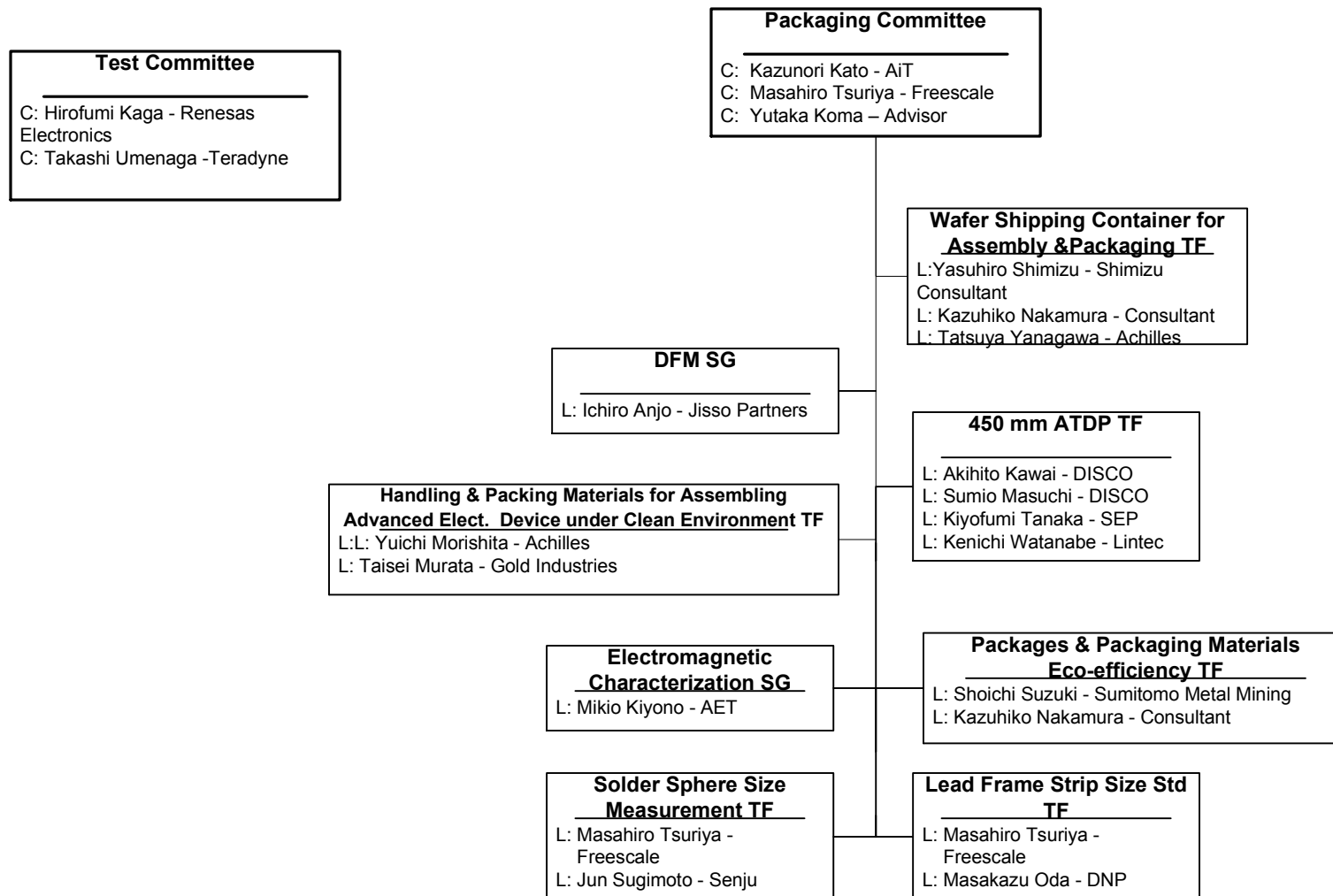

# SEMI Korea Regional Standards Organization

## Facilities Committee

C: Kwang Sun Kim - KUT  
C: Insoo Cho - Shinsung ENG

## Information & Control Committee

C: SeokGi Jeong - KC-Tech  
C: Chul Hong Ahn - Hynix  
C: Gun Woo Lee - Miracom Inc.

## EHS WG

L: Seung Jong Ko - Hynix  
L: Hyunsuk Kim - Samsung  
Electronics

## FPD Committee

C: JongSeo Lee - Samsung  
Electronics  
C: Il-Ho (William) Kim - Light  
Measurement Solution

## FPD Metrology Committee

C: JongSeo Lee - Samsung  
Electronics  
C: Il-Ho (William) Kim - Light  
Measurement Solution

# SEMI Korea FPD and FPD Metrology Committees

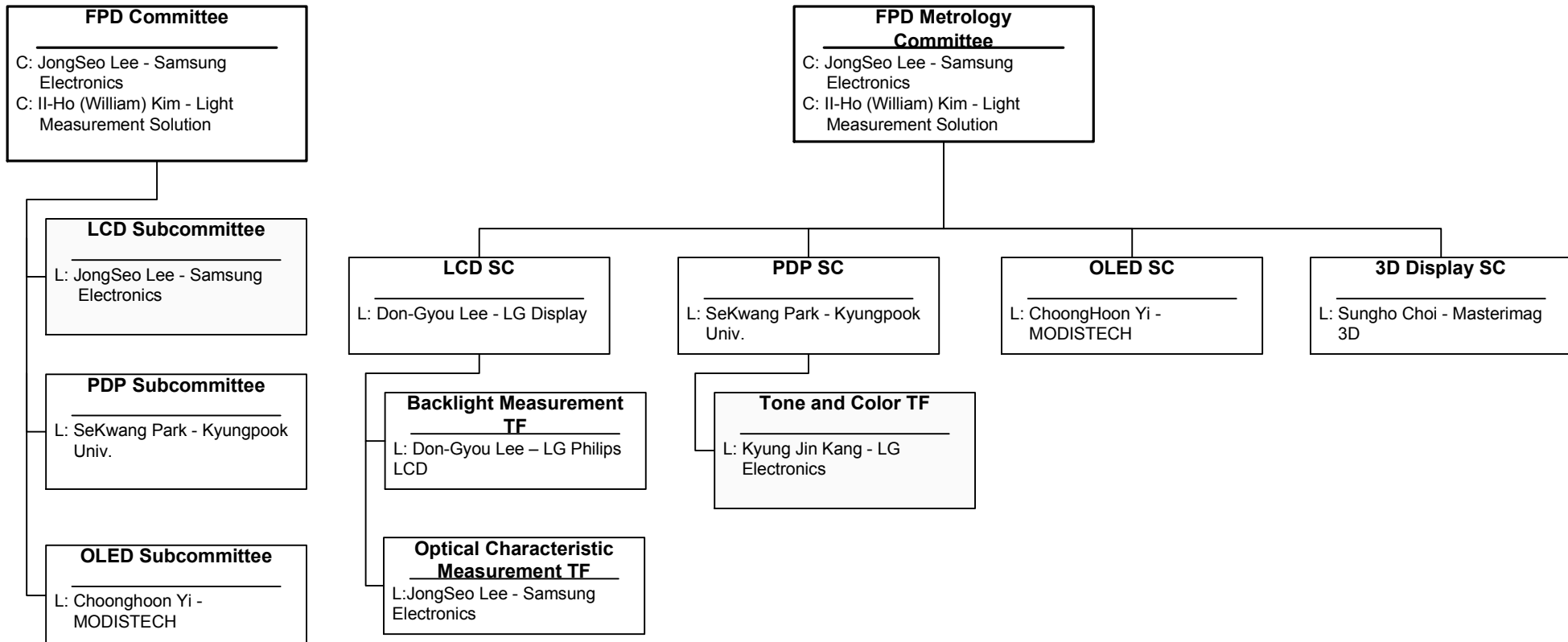

# SEMI Korea Information & Control, Facilities Committees, and EHS WG

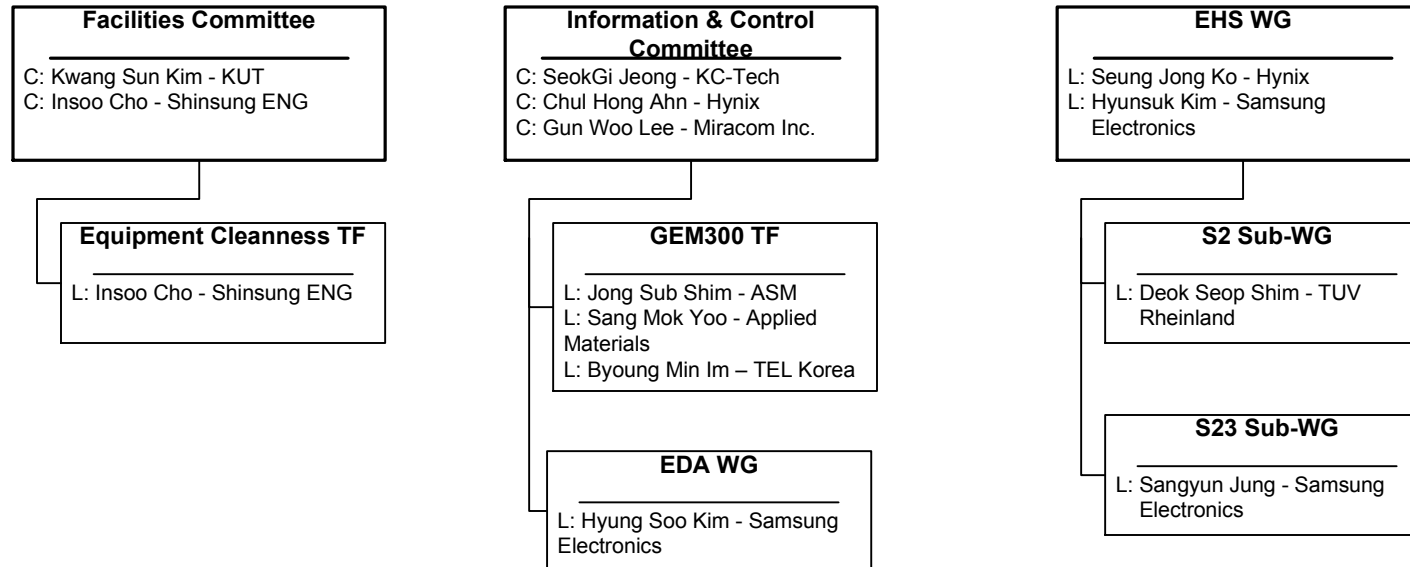

# SEMI N.A. Regional Standards Organization

Co-Chairs: Jackie Ferrell - ISMI & Sean Larsen – Lam Research AG

Vice-Chair: Mark Crockett – MEMSMART

## 3DS-IC

### Committee

C: Richard Allen - SEMATECH  
C: Urmi Ray - Qualcomm  
C: Chris Moore – Semilab  
C: Sesh Ramaswami – Applied Materials

## Flat Panel Display Committee

C: Bill Colbran - Engenuity Systems

## MEMS/NEMS Committee

C: Win Baylies - BayTech Group  
C: Mark Crockett - MEMSMART

## Physical Interfaces & Carriers Committee

C: Matt Fuller - Entegris  
C: Mutaz Haddadin - Intel

## Automated Test Equipment Committee

C: Ajay Khoche – Khoche Consulting

## Gases Committee

C: Tim Volin - Parker Hannifin

## Metrics Committee

C: David Bouldin - Fab Consulting  
C: Mark Frankfurth - Cymer

## Silicon Wafer Committee

C: Dinesh Gupta - STA  
C: Noel Poduje - SMS  
VC: Mike Goldstein - Intel

## Compound Semiconductor Materials Committee

C: Russ Kremer - Freiburger Compound Materials  
C: James Oliver - Northrop Grumman

## HB-LED Committee

C: Iain Black - Philips  
C: Chris Moore - Semilab  
C: Bill Quinn – Veeco  
C: David Reid - Silian

## Microlithography Committee

C: Wes Erck - Wes Erck & Associates  
C: Rick Silver - NIST

## Traceability Committee

C: Win Baylies - BayTech Group  
C: Yaw Obeng - NIST

## Environmental Health & Safety Committee

C: Chris Evanston - Salus Engineering  
C: Sean Larsen – Lam Research AG  
C: Eric Sklar - Safety Guru  
C: James Beasley - ISMI

## Information & Control Committee

C: Jack Ghiselli – Ghiselli Consulting  
C: David Bricker - AMAT  
C: Lance Rist - RistTex

## Photovoltaic Committee

C: Win Baylies - Baytech Group  
C: James Moyné – Applied Materials

## NA RSC Technical Architect Board

C: James Moyné - Applied Materials  
C: Yaw Obeng - NIST

## Facilities Committee

C: Phil Naughton - Applied Materials  
C: Steve Lewis - CH2M Hill

## Liquid Chemicals Committee

C: Frank Flowers - FMC  
C: Frank Parker - ICL

## Photovoltaic Materials Committee

C: Lori Nye – Brewer Science  
C: Dick Hockett – Evans Analytical Group

# SEMI N.A. Gases Committee

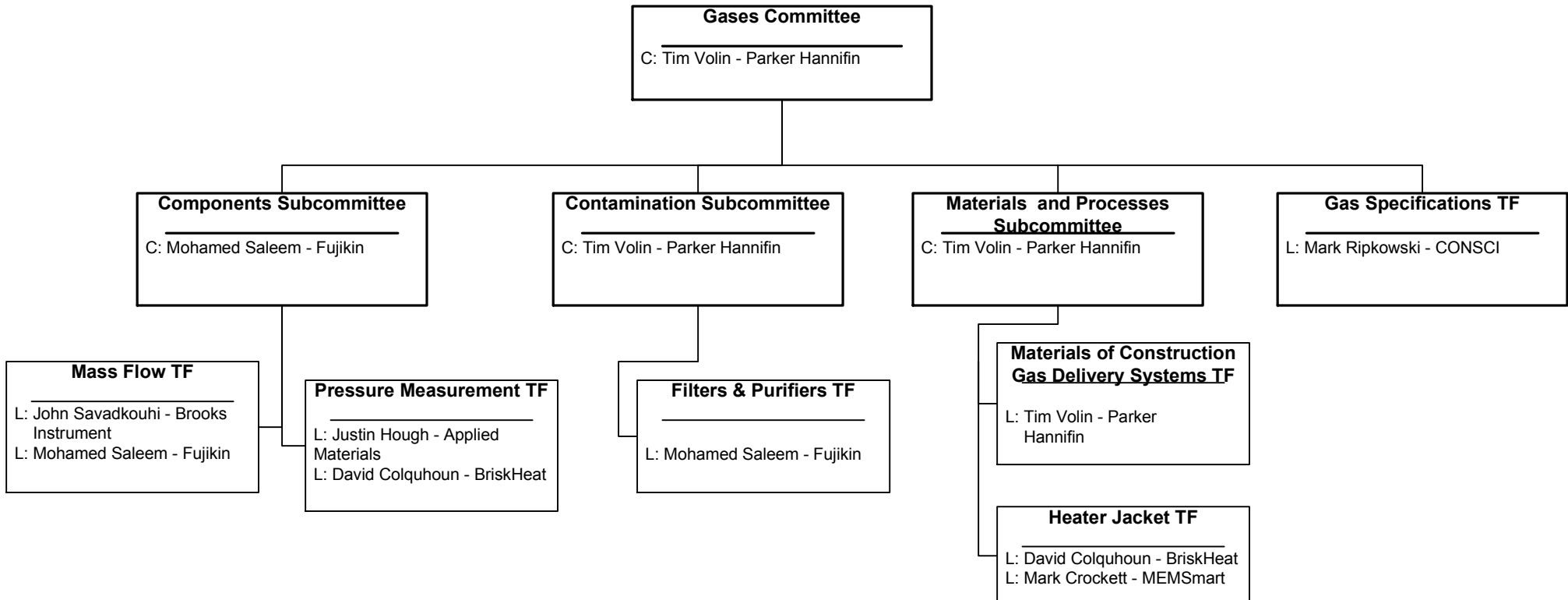

# SEMI N.A. Facilities & Liquid Chemicals Committees

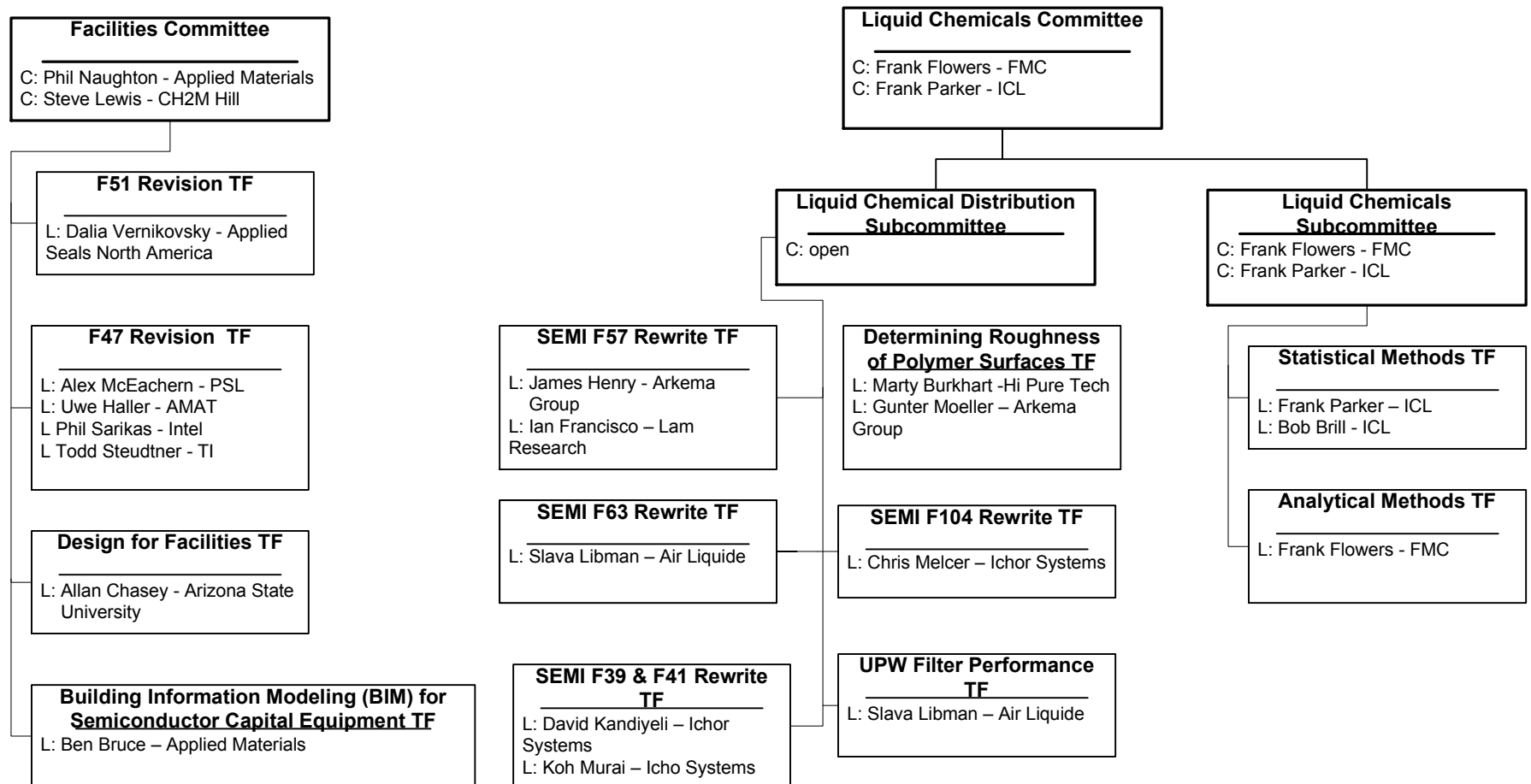

# SEMI N.A. Information & Control and Automated Test Equipment Committees

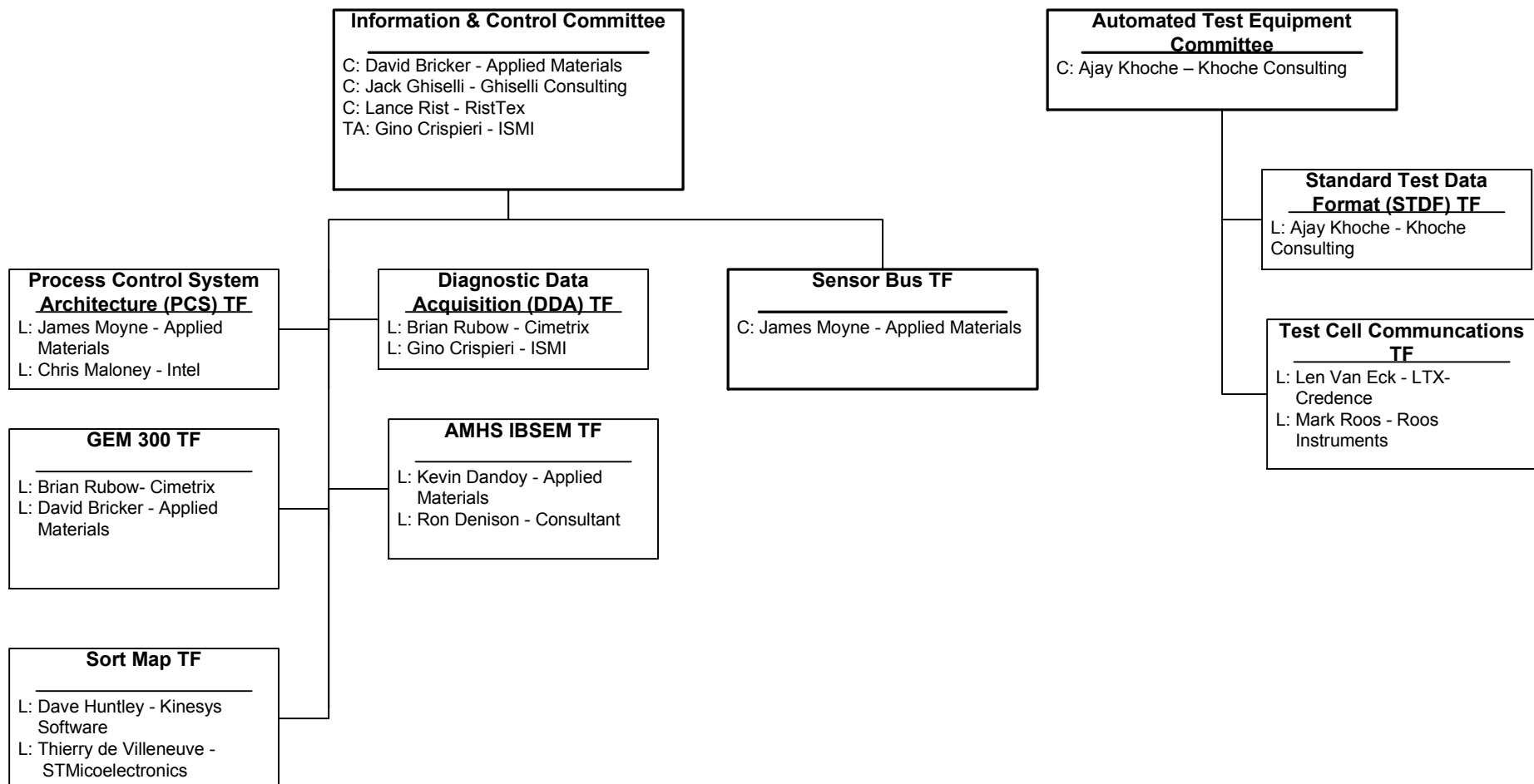

# SEMI N.A. Physical Interfaces & Carriers and Metrics Committees

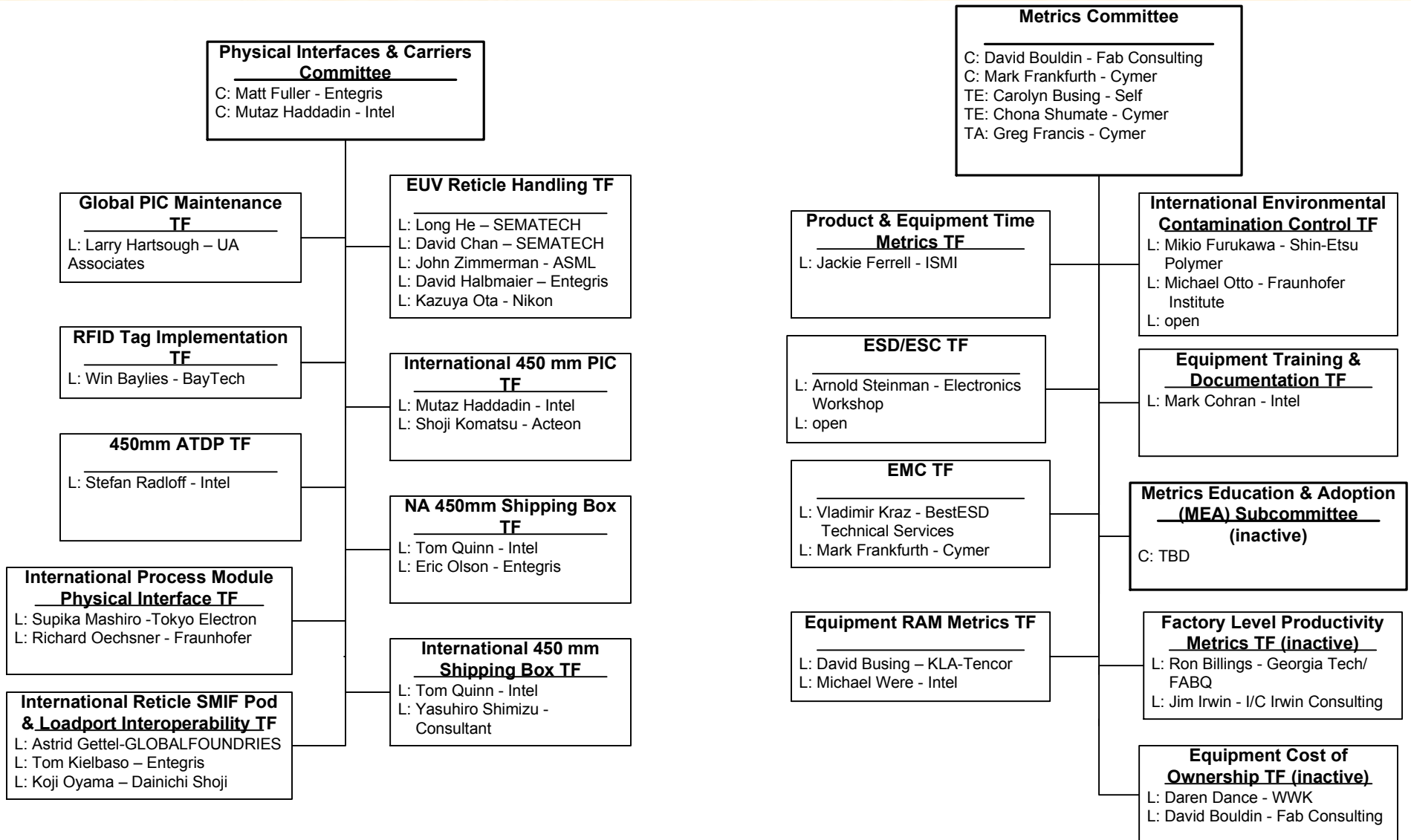

# SEMI N.A. FPD, Microlithography & Traceability Committees

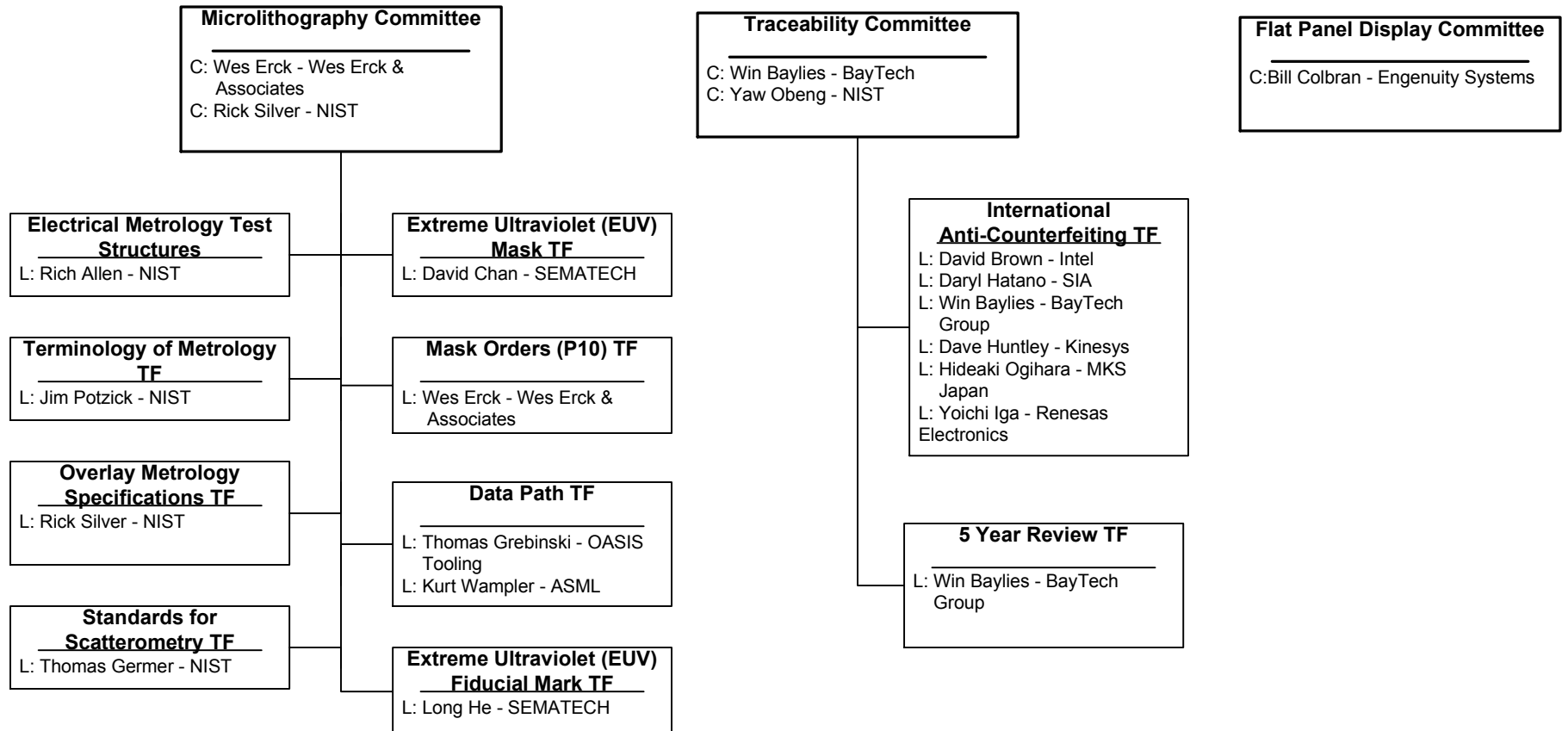

# SEMI N.A. Compound Semiconductor & Silicon Wafer Committees

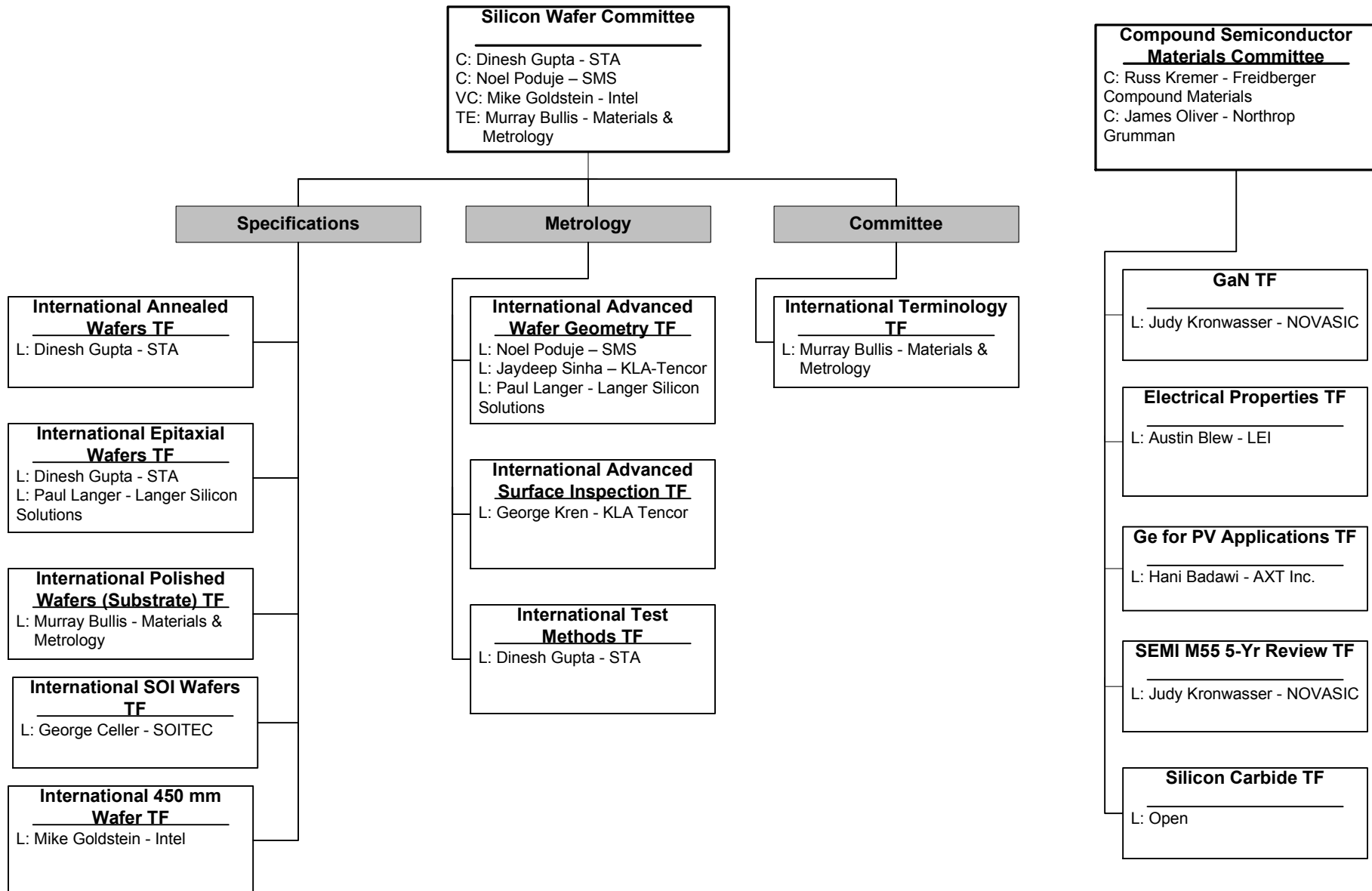

# SEMI N.A. Photovoltaic & Photovoltaic Materials Committees

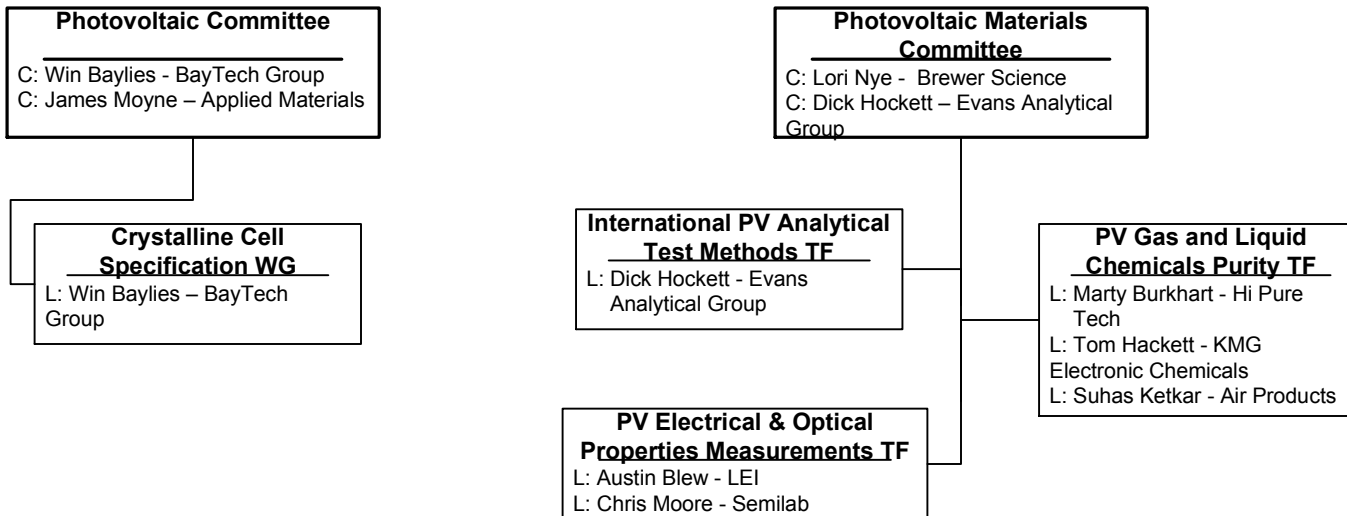

# SEMI N.A. Environmental, Health & Safety Committee

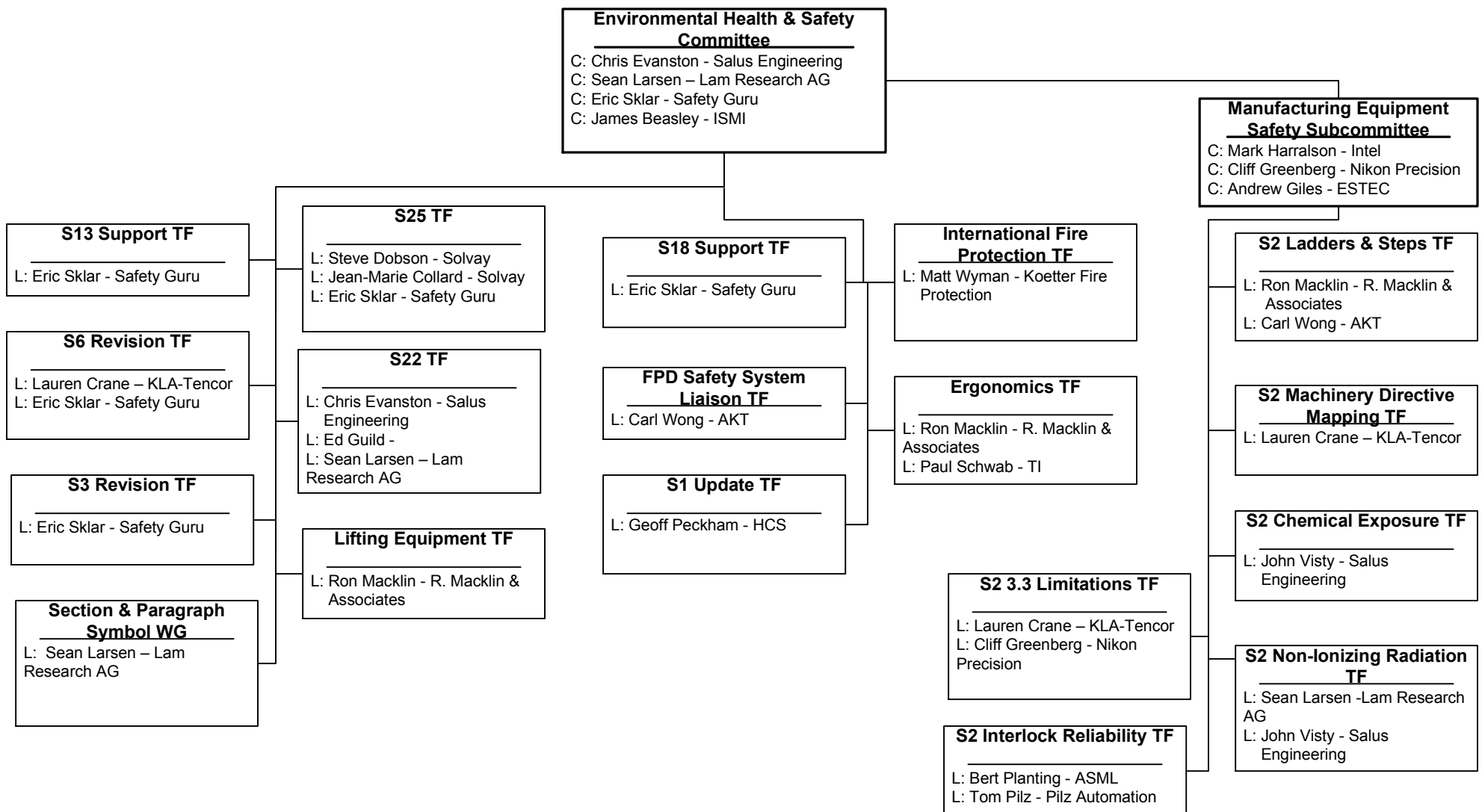

# SEMI N.A. 3DS-IC, HB-LED & MEMS/NEMS

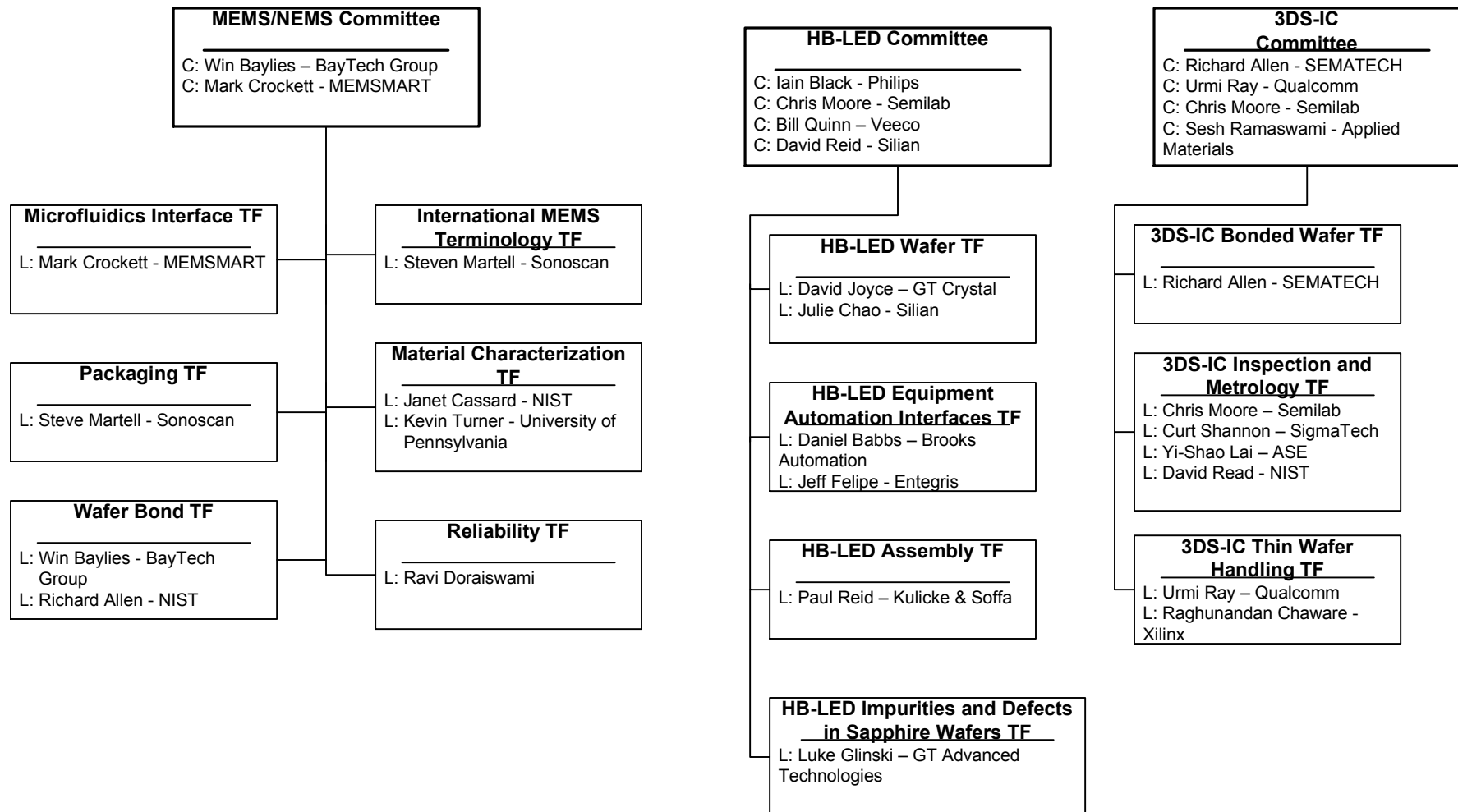

# SEMI Taiwan Regional Standards Organization

**ISC Taiwan Advisor**

Tzeng-Yow Lin - CMS/ITRI

**Information & Control  
Committee**

C: Robert Chien - TSMC

**Environmental Health & Safety  
Committee**

C: S. W. Yu - SAHTECH  
C: F. M. Hsu - TSMC

**Flat Panel Display Committee**

C: Tzeng-Yow Lin - CMS/ITRI  
C: Jia-Ming Liu - TMDA

**Photovoltaic Committee**

C : B. N. Chuang - CMS/ITRI  
C : J.S. Chen-TeraSolar  
C : Ray Sung-UL Taiwan

**3DS-IC  
Committee**

C: Tzu-Kun Ku - ITRI  
C: Wendy Chen – King Yuan  
Electronics  
C: Yi-Shao Lai - ASE

# SEMI Taiwan Information & Control and Photovoltaic Committees

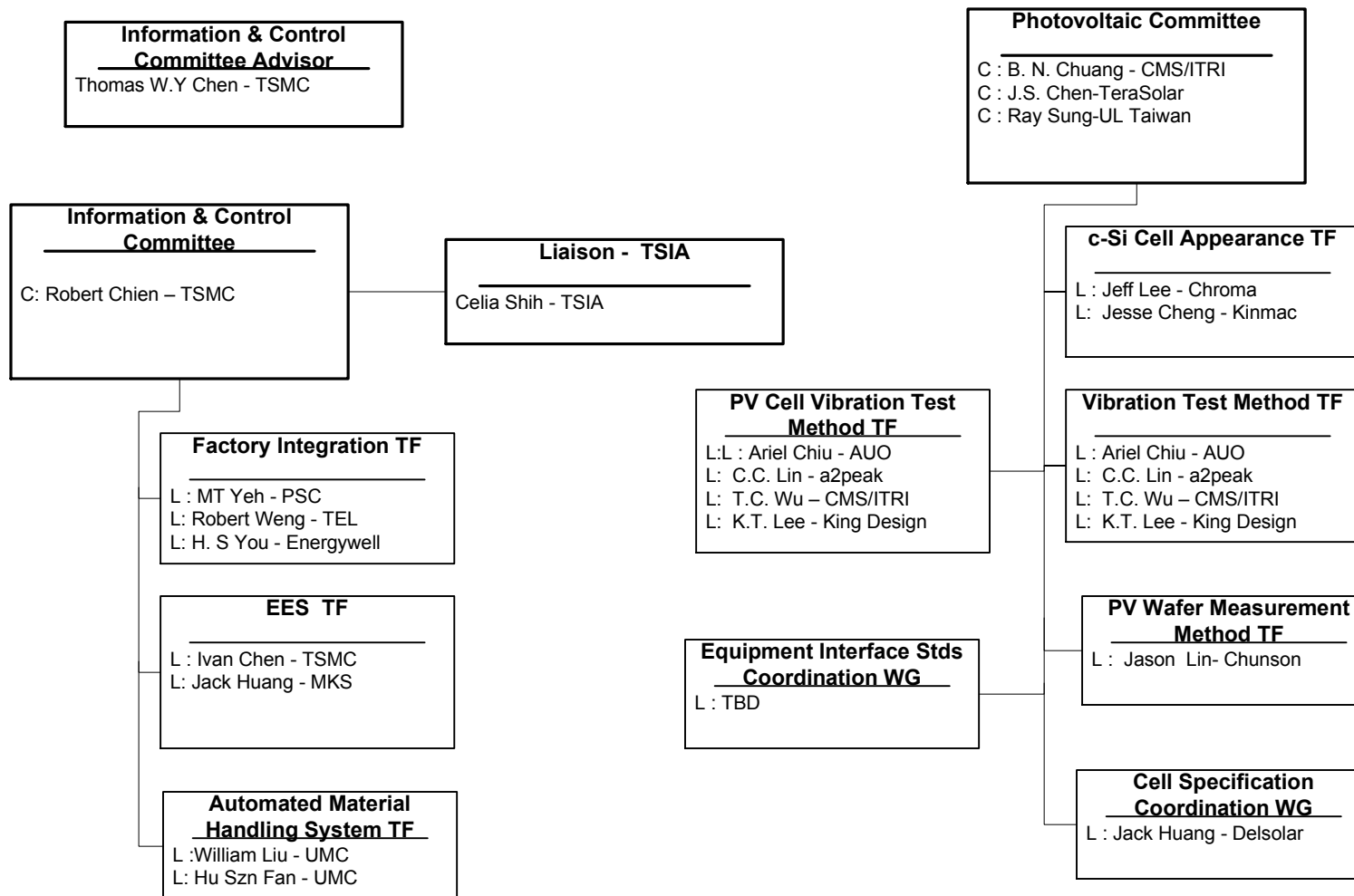

# SEMI Taiwan 3DS-IC & Environmental, Health & Safety Committees

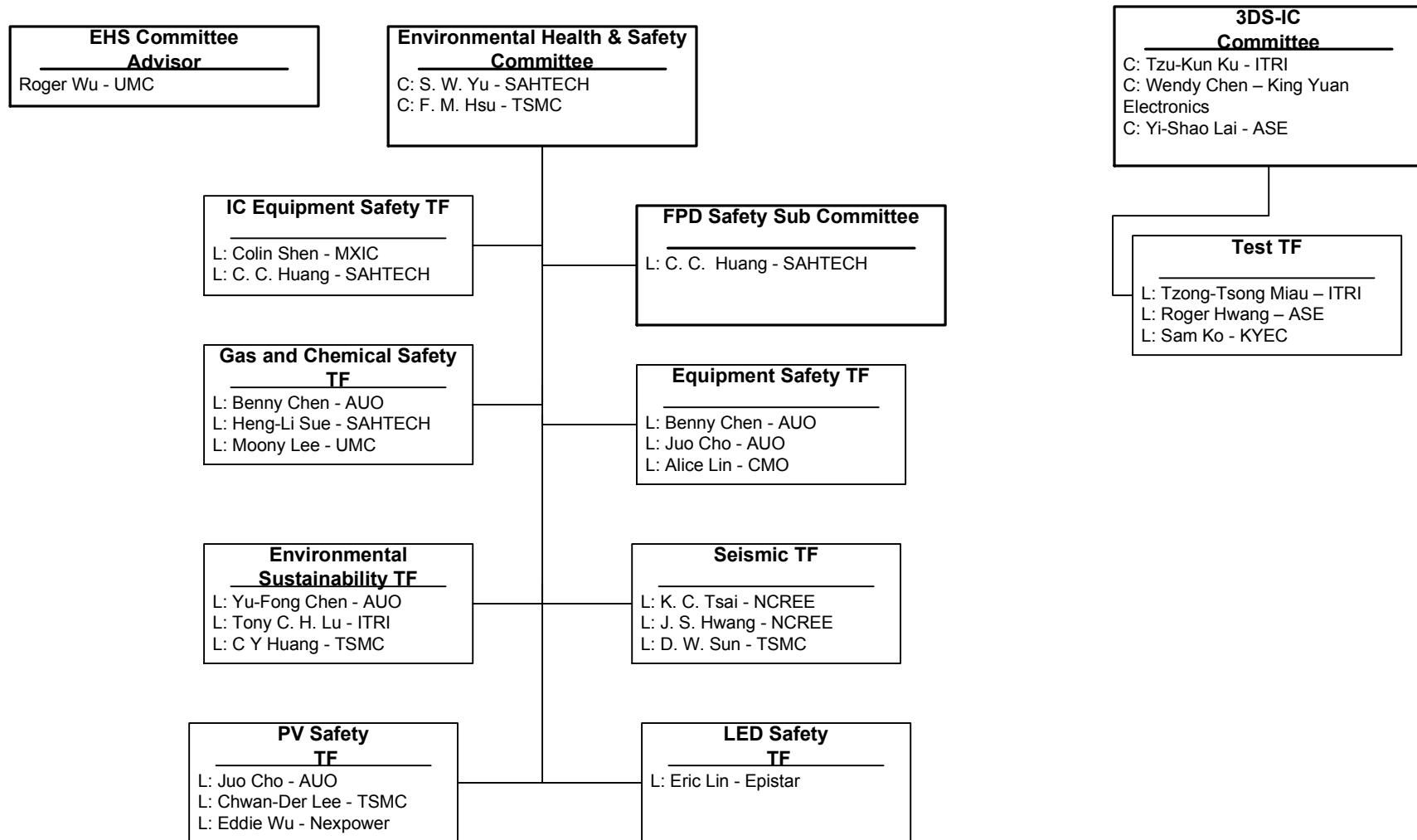

# SEMI Taiwan Flat Panel Display Committee

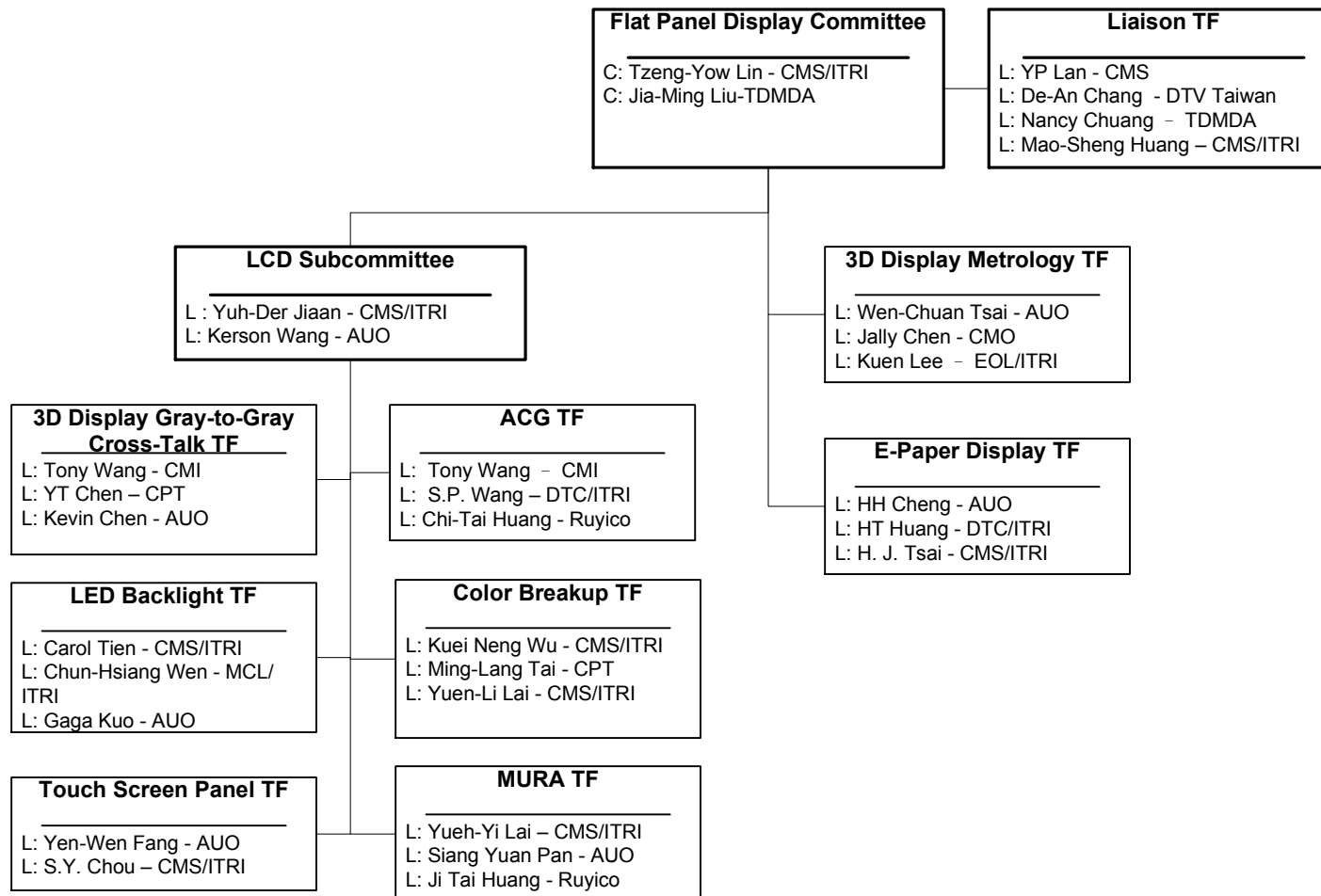

# SEMI China Regional Standards Organization

